

**Manufacturer:**

**UNIFOREST** d.o.o.  
Dobriša vas 14/a 3301 PETROVČE  
SLOVENIA TEL.: +386 3 713 14 10  
[info@uniforest.si](mailto:info@uniforest.si)

## **Instructions for use**

### **FORESTRY WINCHES**

**65H / 85H / 65Hpro / 85 Hpro**

**Instructions for safe work**

**Spare parts list**



## Index

Technical data .....	4
Instructions for safe work .....	5
Instructions for use .....	9
Settings .....	13
Maintenance .....	17
Removal of faults .....	19
A list of replacement parts .....	22
A list of hydraulic replacement parts .....	28
Declaration .....	32

## **FORESTRY WINCHES 65H/ 85H / 65Hpro / 85Hpro**

### **Dear customer!**

We are pleased that you decided to purchase our machine. Forestry winch is a forestry machine of modern design, whose construction enables effective and safe work in the forest. Work in the forest can only be safe if you follow the instructions for safe work and use. Upon following all instructions, the machine will operate flawlessly, and you will avoid unnecessary costs. We recommend reading the instructions carefully. If you are not sure about something, you can also contact us. We wish you safe work.

### **1. Intended purpose**

The machine is intended exclusively for normal work in the forest. Any other use outside of this framework holds as unintended. The manufacturer is not liable for damages, resulting from unintended use. In this case, the user is the sole bearer of risk. Intended use also includes regarding operational, service and maintenance conditions, which are prescribed by the manufacturer. Only persons, who are trained and acquainted about the dangers and consequences, which can result from improper use, can operate the machine. Relevant safety regulations must also be followed, including generally valid safety-technical, occupational medicine and road traffic regulations. Own interference and modifications of the machine exclude the manufacturer's liability for damages resulting from this.

## 2. Technical data:

	<b>Unit</b>	<b>65H</b>	<b>85H</b>	<b>65Hpro</b>	<b>85Hpro</b>
<b>Connection</b>	category	1	1	1	1
<b>Pulling force</b>	kN	65	65	85	85
<b>Brake force</b>	kN	81,25	81,25	106,25	106,25
<b>Wire rope medium speed</b>	m/s	0,60	0,60	0,60	0,60
<b>Wire rope maximum length</b>	mm/m	11/135	11/135	12/128	12/128
	mm/m	12/115	12/115	11/150	11/150
<b>Wire rope length (serial)</b>	mm/m	12/80	12/80	13/90	13/90
<b>Tractor required power</b>	kW	40-70	40-70	>50	>50
	PS	55-95	55-95	>70	>70
<b>Rated strength</b>	N/mm <sup>2</sup>	2160	2160	2160	2160
<b>Width</b>	mm	1685	1800	1800	2000
		□1800		□2000	
<b>Depth</b>	mm	750	750	750	750
<b>Height without protective net</b>	mm	1690	1690	1690	1690
<b>Height with protective net</b>	mm	2300	2300	2300	2300
<b>Weight (without wire rope)</b>	kg	560	580	595	622
<b>Revolutions on cardan</b>	min-1	max 540	max 540	max 540	max 540
<b>Unwinding device</b>		□	■	□	■

□ Option ■ Serial

## INSTRUCTIONS FOR SAFE WORK

When operating the winch, you must devote maximum attention to safety! To prevent accidents, carefully read and follow the instructions below.

### General:

1. Beside guidelines in these instructions for use, follow also all generally valid safety and accident regulations.

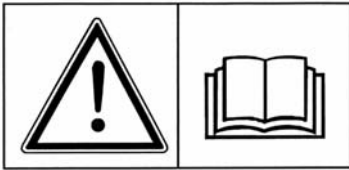

2. The winch must be operated safely and regulations regarding safe work must be followed.
3. Only persons, who are older than 18 years, can operate or work with the winch.
4. Warning plates on the machine provide important instructions for safe operation. Follow them for your own safety.
5. The winch or its flawless operation must be checked before each use or at least once per working day. Defects must be eliminated professionally. The winch must be professionally inspected by an expert before first use and after major modifications or at least once a year.
6. When using public traffic routes, follow the signs and traffic regulations.
7. When working, it is obligatory to use personal protection equipment (helmet, gloves, appropriate footwear...).
8. Before taking off and inclusion, control the vicinity (children). Ensure adequate visibility.
9. Driving on winch during transport is prohibited.
10. The winch must be connected according to the instructions.
11. For road transport, prepare the machine as prescribed. If the winch covers the rear lights of the tractor and are not visible during transport, additional lights must be installed for driving on the road.
12. Drive speed must always be adjusted to environment conditions. When driving uphill or downhill and transversally to slope, avoid sudden turns.
13. Do not stand in the danger area.



14. Nobody is allowed to stand between the tractor and the winch, if the tractor is not secured against movement with hand brake or with a wedge.



15. Until all winch elements are not still, it is prohibited to touch it.

16. Regularly check tightness of bolts.

17. The winch must be visually inspected before use. At least once a year, a professionally trained person must conduct an inspection.

18. The winch must not be used for other purposes (e.g. for lifting load – figure 5).



19. With each intervention in the winch, the PTO shaft or the tractor must be shut down.

20. It is prohibited to remove protective elements on the winch.



21. Rope of appropriate strength and quality must be used for towing rope (see factor plate).

22. Damaged wire rope must be replaced immediately.

23. It is obligatory to use wire ropes of such length that, at full winding on the drum, the distance 1.5 of rope diameter to outside drum diameter remains. When unwinding the rope, a minimum of two windings must remain on the drum.

24. Assistant must not connect load to the winch, if the tractor operator is not aware of it.

25. It is especially dangerous to stand under the tree, which is to be towed (figure 1).

26. When using diverting pulley, there is a triangular area, which represents a danger



Figure 1

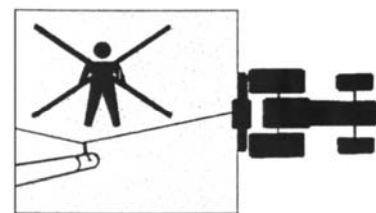

Figure 2

27. When towing, respect the maximum allowed angle of 30 degrees (figure 3).
28. On dangerous terrain or with disregarding maximum allowed towing angle, danger of tipping over exists (figure 4).

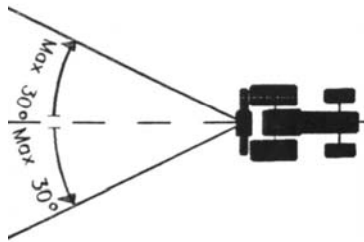

Figure 3



Figure 4

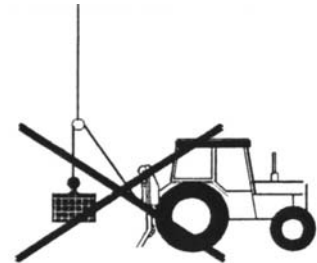

Figure 5

29. Do not stand in the danger zone (figure 4).



30. The winch is not intended for lifting loads (figure 5).
31. Tractor operator and assistant must communicate constantly during work.
32. Winch operator must constantly observe the load during towing. If the terrain configuration does not allow it, the assistant must help him with this task.
33. The tractor, on which the winch is installed, must have a minimum tyre profile, which is still in accordance with road regulations. If not, chains must be installed on the wheels. Chains are also obligatory when working on snow and ice.
34. When disconnecting, you must first choose a solid and flat surface. The winch must be fixed with the help of support legs. PTO shaft is put on the prepared holder.
35. In the area of three-point hitch, there is a danger of injury, because of crushing and impact.
36. The winch can be operated only from a safe position, where the operator is not exposed to the danger of the load, rope, hook or the winch itself. A safe place is also the tractor seat, if the winch is fitted with an appropriate sized safety net. When operating the winch outside the tractor seat, the operator of the winch must have sufficient protection, e.g. with the tractor itself, with a safe position with adequate distance from the vehicle, e.g. behind a tree. Timber can be attended to from the side by the connection; shorter wood can be attended to diagonally behind the load (figure 6).

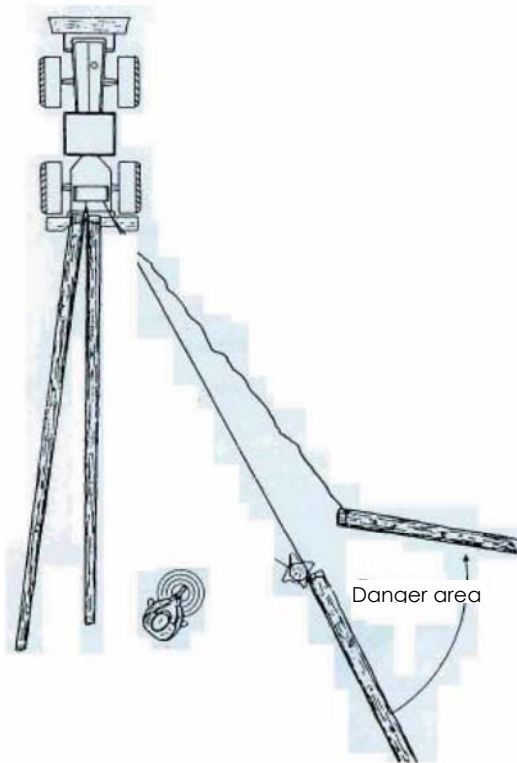

Figure 6

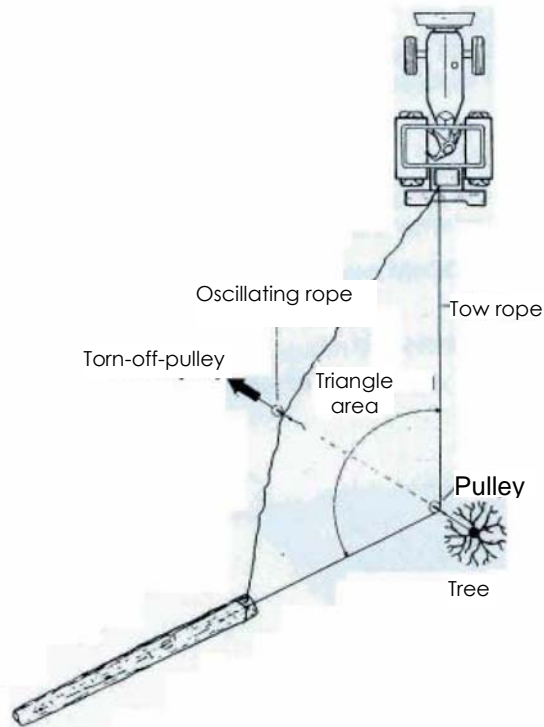

Figure 7

37. During towing, standing between the load is prohibited (figure 7).

38. For towing, use only low expansive rope of adequate strength, which are given on the winch type plate and in the manufacturer's instructions.

### PTO SHAFT

1. Only PTO shafts, which are prescribed by the manufacturer, can be used.
2. Cardan protection pipes and protection funnels and connection protection must be installed, which must be in perfect condition.
3. With PTO shafts, be careful with prescribed pipe protection in transport and working position.
4. Connect and disconnect the cardan only when the cardan power take-off is disengaged, the engine is stopped and the ignition key is removed.
5. Always be careful to install and secure the cardan correctly.
6. Protect the cardan protection from rotation with hang chain.
7. Before engaging the PTO shaft on the tractor, make sure that the chosen number of revolutions and rotation direction comply with the requirements, given in the technical data chapter.
8. Before engaging the PTO shaft, be careful that nobody is standing in the machine's danger zone, which applies also to operation.
9. PTO shaft must never be engaged, when the engine is stopped.
10. Put the disconnected PTO shaft on the foreseen holder.



## INSTRUCTIONS FOR USE

### DESCRIPTION

The winch is a machine intended for storing chopped logs from the forest. Basic parts of the winch are: welded housing, drive part, drum with shaft, clutch, brake, upper and lower pulley and other smaller elements. Control is done by electro hydraulic system. Clutch and brake are engaged by hydraulic cylinders. Pressure in the hydraulic part is created by the hydraulic pump, which is driven by the PTO shaft. Hydraulic battery maintains required pressure in the system even after the pump becomes still or the tractor is shut down, which still enables to unwind the wire rope. Steering elements are powered by electricity from the electrical socket at the rear of the tractor. The winch operates with hydraulic pressure to maximum 160 bar.

**Safety valve is factory set and the pressure is not allowed to be increased!**

### REQUIRED EQUIPMENT OF THE TRACTOR

- PTO shaft with chosen gear ratio, max. 540 RPM.
- Three-point hitch of I and II category.
- electrical installation 12 V with socket on the rear of the tractor



**Maximum number of revolutions and direction of tractor PTO shaft rotation is 540 min<sup>-1</sup>.**

### PTO SHAFT ADJUSTMENT

Length of PTO shaft needs to be adjusted for different tractors (figure F1-F4). For winch 65H/85H/65Hpro/85Hpro, the use of PTO shaft with torque 695 Nm (type W 400E Walterscheid) is appropriate.

Ascertain the accurate length in the following manner:

1. Shut down the tractor.
2. Connect the machine to the tractor.
3. Extract the PTO shaft apart and connect the individual shaft halves to the tractor and machine and compare them crosswise and mark them (figure F1).
4. Shorten external and internal plastic protection pipes (figure F2).
5. Shorten external and internal slide profiles with the same distance as plastic protection pipes (figure F3).
6. Crop the pipe end, remove fillings and grease the slide positions well (figure F4).

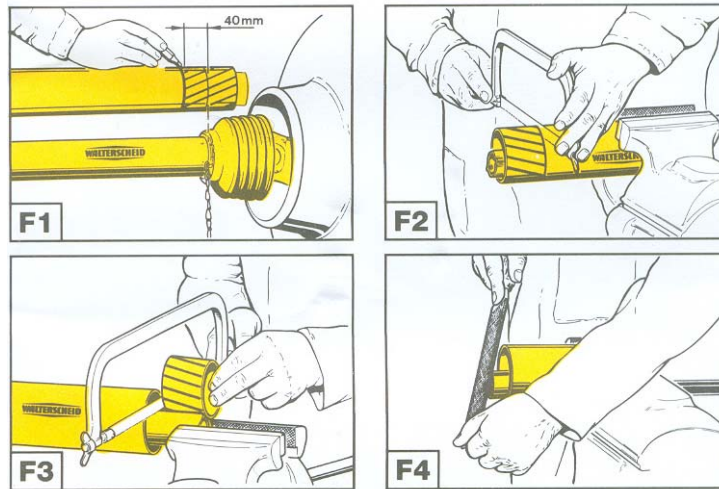

## TRACTOR MOUNTING

**When connecting the winch, do not stand in the danger zone!**



Forestry winch can be connected to any tractor, which has a three-point hitch, with connection frame of category I or II. Appropriate construction also enables easy connection to the tractor with automatic connection rods. Connect the prescribed PTO shaft and secure cardan protection with a hang chain. Be careful that the cardan clicks into place on both connection points! For transfer of torque from the tractor to the winch, it is advisable to use a PTO shaft with a clutch. Once the winch is attached to the tractor, strengthen the stabilizers on the lower connection rods and level the winch with a hitch nut into position, so that the winch is tilted backwards for approximately 20 degrees. Electrical cable plug on the winch is connected to the socket on the tractor. Steering console is connected to the socket on the winch housing. When using remote control, receiver cable is connected to the socket, where the steering console used to be.

## **WIRE ROPE UNWINDING**

When the winch is properly connected, we can begin with unwinding of the wire rope. On tractors without a socket with constant current of 12 V, we can connect a supply cable in the socket, which is usually made for connection of light equipment on the trailer. Because of this, we have to turn on the position lights.

On the steering console (figure 8), press the left button to release the brake. Hydraulic cylinder shifts to position 1. If we disengage pressure on the button in less than 3 seconds, the brake cylinder shuts and the winch is again open and unwinding is not possible. If this button is pressed for more than 3 seconds, the function shifts from "impulse" to "constant release" and despite not holding the button, the cylinder stays in the open position and the winch in unwinding function.

When unwinding, we have to be careful not to unwind the wire rope completely or leave at least three winds on the drum. This distance is marked on the wire rope. Due to safety reasons, the wire rope is installed on the drum so that if the logs start to slide without control, the rope must "pull" itself off the drum. If the rope was pulled out with excessive force, we can pull out the entire wire rope during pulling. In this case, replace it according to the procedure, foreseen for wire rope installation.

If the wire rope is very tight and we wish to release it, we have to do it impulsively with quick presses 2-3 times on the left button. This prevents the wire rope to unwind too quickly from the drum and that the wire rope is not too loose. It also prevents the logs to slide downhill.

### **Warning**

**Steel rope must be completely unwound before first use and wind it back on the generator drum under load.**

For instance, we can do this so that we attach the rope to a standing tree and pull the tractor with slight braking to the tree. This procedure must be done also before trying to tow, if we towed downhill beforehand or if the rope was wound loosely during towing.

### **ATTENTION!**

Loosely wound steel rope can be damaged (stuck, bent) at greater load, so that it is prohibited to use it again.

**Warranty does not apply for a steel rope, which is damaged in such manner.**

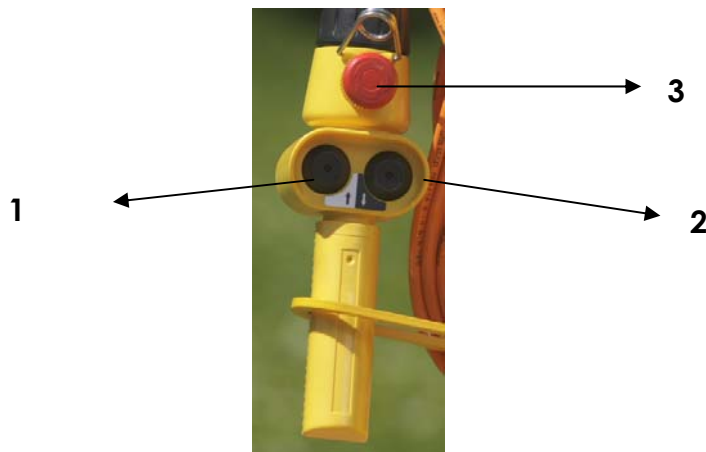

## WINCH CONTROLER

We can start pulling, when the winch is on the ground and properly strengthened. Apply the hand brake on the tractor. If the PTO shaft is engaged and the hydraulic system requires pressure, we can start pulling. Press the right button on the steering console (pos. 2, figure 8). The wire rope starts winding on the drum. When we release the button, the winding stops.

**If the unwinding of the wire rope does not stop immediately after releasing the button, the winch is malfunctioning. Immediately stop work and contact service company, because operating the winch in this case is deadly!**

**During pulling it is forbidden to lift the winch, because this can damage the connection PTO shaft on the winch.**

**In case of ultra vires or danger of accident, immediately press the red button (pos. 3) to put the winch in a standstill.**

## SETTINGS

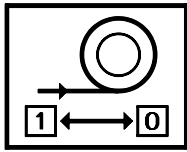

Figure 9

## CLUTCH

**Before any modification on the winch, shut off the tractor engine!**

Pulling force on the clutch is factory set and does not require to be changed. Due to wear of friction surfaces, distance between clutches needs to be set after a certain period. This is done once a year at usual work in the forest or after every 1000 m<sup>3</sup> of pulled out logs, but not before end of warranty period.

Perform the setting by unscrewing the nut (pos. 9, figure 11), which is the safety nut, to the left. Then, tighten the high nut (pos. 15, figure 11) to the right. In this position, there is no distance between the clutches. Then, unwind the nut for one turn to the left – this creates a gap between the lamellas of approximately 4-5 mm. Retighten the safety nut (pos. 9, figure 11) to the right. This protects the high nut from unwinding. Engage the motor and PTO shaft, pull out the rope and begin controlling the adjustment.

If, despite not engaging the right button for pulling, the rope starts to move, then the distance between the clutches is too small. Increase it for approximately 1 millimeter or repeat the setting procedure by unwinding the high nut for ¼ of a turn to the left. Engaging pulling is not allowed, if the nuts (pos. 9 and 15, figure 11) are not installed on the shaft, because the hydraulic cylinder of the clutch gets damages, because the maximum permitted travel is only 8 mm!

**WARNING If the cylinder stroke is greater than 8 mm, oil can leak on clutches.**

## PRELIMINARY BRAKE

Set the pre-brake with screw (pos. 4, fig. 11) and nut (pos. 5, fig. 11). By rotating the bolt to the right, the brake force is increased, with rotating to the left, the brake force is decreased. Then tighten the wing nut, which prevents the bolt to loosen automatically. Proper setting ensures that the wire rope does not roll off the drum automatically or excessively. This would cause loose winding and damage to the wire rope at fast disburdening of the brake and unwinding. Preliminary brake is properly set when unwinding of the rope is still possible without excessive effort. If you pull the rope uphill, it is possible to additionally disburden the brake, so that rope towing is easier, the bolt (pos. 4, figure 11) must be returned to its original position immediately after.

## BRAKE

At the end of pulling, the differential brake automatically engages. Brake is factory set to brake force, which is 25% greater than the nominal towing force of the winch. By wear of the brake pad, the brake force changes, therefore it has to be set again. This is needed, when the brake does not hold the load as described in the beginning of this paragraph. Set the brake force by loosening or tightening the screw (pos. 2, fig. 11) and loosen the safety nut (pos. 3, fig. 11) beforehand. When tightening the screw (pos. 2, fig. 11), the brake force decreases, and when loosening the screw, the brake force increases. After finishing setting tighten the safety nut (pos. 3, fig. 11). Correctly set band brake in the on position disables the load to slide backwards, and in the off position, it enables smooth pulling of the rope from the winch.

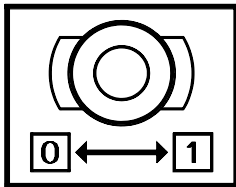

Figure 10

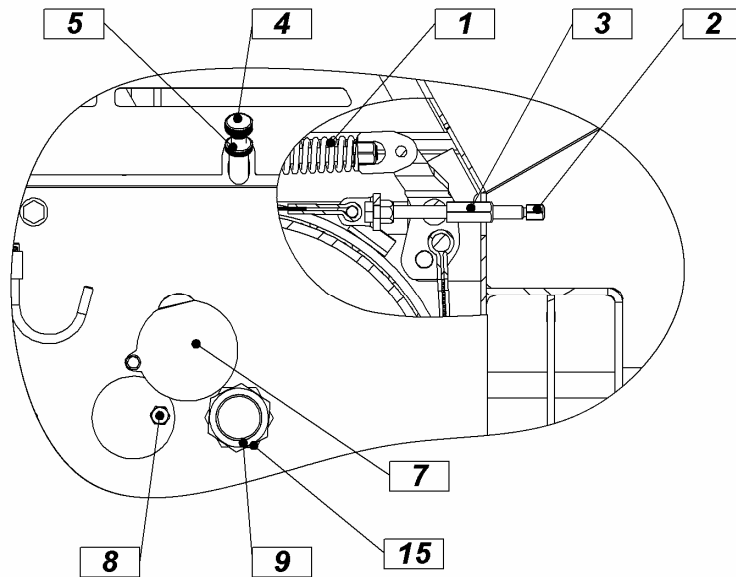

Figure 11

## **DRIVE CHAIN TENSIONING**

After a certain period of operation (10 hours), the drive chain stretches; therefore it must be checked frequently and tensioned, if required. It must be checked every 500 hours of operation. Tensioning is done according to the following procedure (figure 12)! First, disengage the PTO shaft and turn off the engine. Remove the protective sheet of the PTO shaft (pos. 1,fig.12)).

Loosen the nuts (pos. 2, pos. 8, fig. 12), which fix the lower drive (pos. 3 , pos. 9, fig. 12). Then loosen the safety nut (pos. 12, fig. 12) and use screw (pos. 13, fig. 12) to tension the longer chain (pos. 6). Turn this screw to the right until you set the correct tension of the chain. Chain is correctly tensioned when it still swings approx. 3 to 4 mm in the transverse direction. Then, with the counter-nut (pos. 12, fig. 12), tighten the screw, which prevents the tensioning device to loosen. Now securely tighten all four nuts on the lower drive (pos. 2, fig. 12). Then start to tension the shorter chain (pos. 8, fig. 12). If you have already loosened the four nuts (pos. 8, fig. 12), loosen the nut (pos. 11, fig. 12) and start turning the tensioning screw (pos. 10, fig. 12) to the left. This increases the distance between both housings. When the chain (pos. 7, fig. 12) is properly tensioned, tighten the nut (pos. 11, fig. 12) and other nuts (pos. 8).

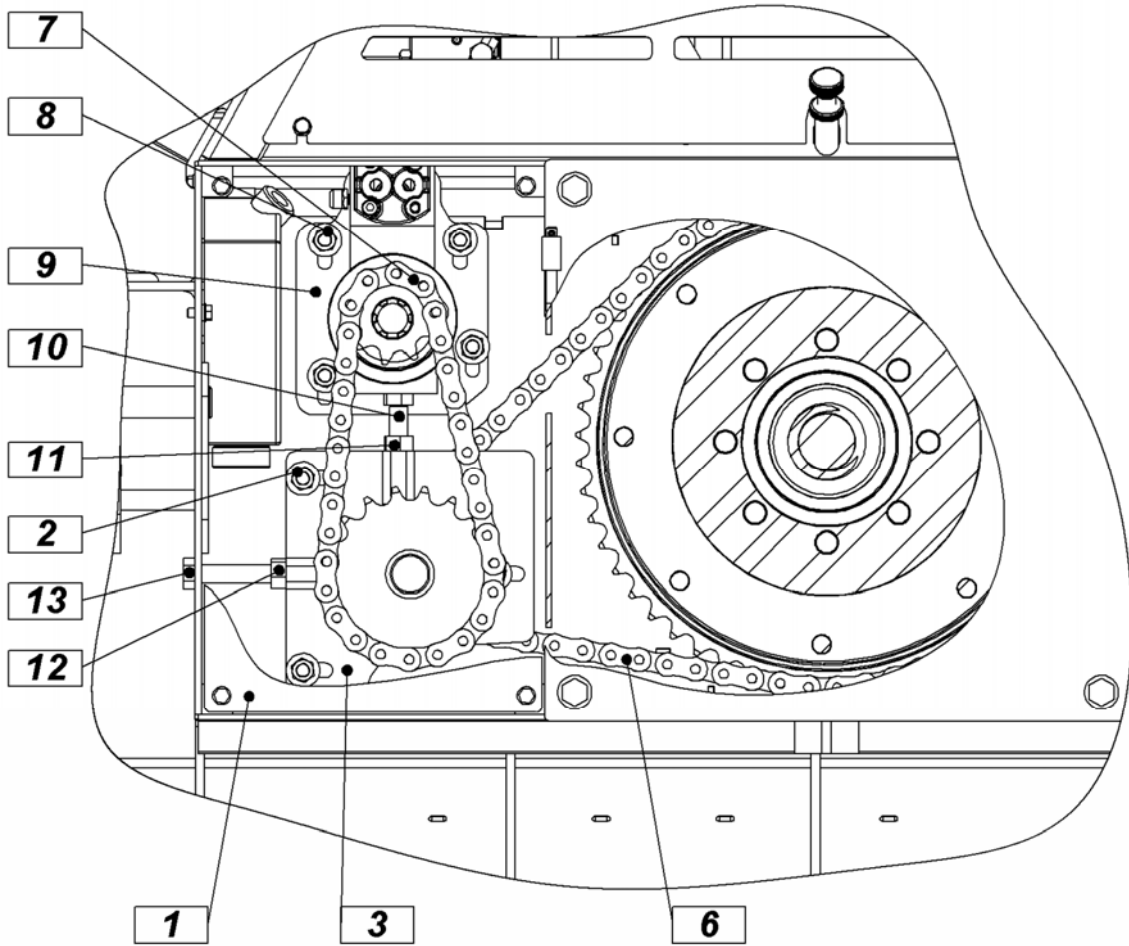
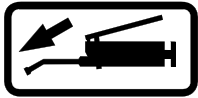

Figure 12



## WIRE ROPE ASSEMBLY

First, remove the triangular protective net on the winch column. Then rotate the cover (pos. 7, figure 11) and rotate the drum in a position, which enables unscrewing of the bolt (pos. 8, figure 11) on the drum. Insert the wire rope in the guide of the upper pulley and direct it through the upper pulley to the rope drum. Insert the rope in the groove and tighten the bolt (pos. 8). Then start to wind according to the procedure, which applies to towing. Once the entire length of the wire rope is wound, unwind it again and wind it again strongly according to the procedure, which is described in the chapter "Wire rope unwinding" to prevent damage to the rope.



### MAINTENANCE LUBRICATION

**Before proceeding with maintenance work, shut down the engine, remove the key and wait for all moving parts to stop.**

There is a grease fitting on the winch, which enables greasing of the upper pulley and guide. The second grease fitting is on the housing of the lower pulley. Greasing is required every 60 hours of operation. The PTO shaft needs to be lubricated according to instructions of the manufacturer.

**Non-frequent greasing can cause wear of slide elements and consequentially a defect, which is not subject to warranty terms!**

Drive chain must be lubricated every 200 hours of operation. Lubricate it with spray for lubrication of chains or special grease, which does not melt at high temperatures, because the grease can come into contact with friction coating of the clutch.

First, remove the cardan shaft protection, which must be fitted back after finishing lubrication. Clean the chain before lubrication. Do not lubricate the part, where the grease can reach clutch with application.

**If grease comes into contact with friction coating of the clutch due do improper and excessive lubrication, this would mean a drastic reduction in pulling force and consequentially it would be required to replace the blades of the clutch, which cannot be a subject of this warranty!**

All other bearings on the winch are of closed type, therefore greasing is not necessary.

## CONTROL OF HYDRAULIC OIL

Oil level in the tank needs to be controlled occasionally.

**Oil level in the tank is 3 liters.**

Hydraulic system uses oil for hydraulic systems ISO 32. First oil change must be done after 100 hours of operation. Each next change must be done after 1000 hours of operation or at least once a year. Oil temperature must be checked during operation. If it exceeds 70 °C, the cardan must be stopped and determine the cause of overheating. If you do not have a thermometer present, you can determine the oil temperature by touching the hydraulic line. This must be done only with the engine switched off or else the hydraulic system can malfunction. Oil level is controlled with stick on the tank cover (fig. 13). Here you also fill in oil. With any work on the hydraulic system, pressure in the system must be released. Do this by pressing the left button on the control console (pos. 1, fig. 8) several times, until the pressure drops to 0 bar (pos. 1, fig. 14). Remove the triangular protection on the winch pillar and cardan protection beforehand. Release the oil from the tank (fig. 13) on the tube, which goes from the pump to the tank. There is a filter on the bottom of the tank, which must be replaced with every oil change. High-pressure filter (pos. 2, fig. 14) must also be cleaned.

Replenishing of oil

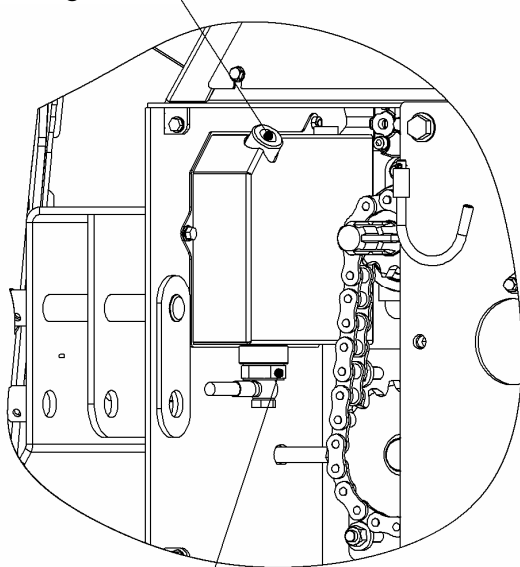

Release of oil

Figure 13

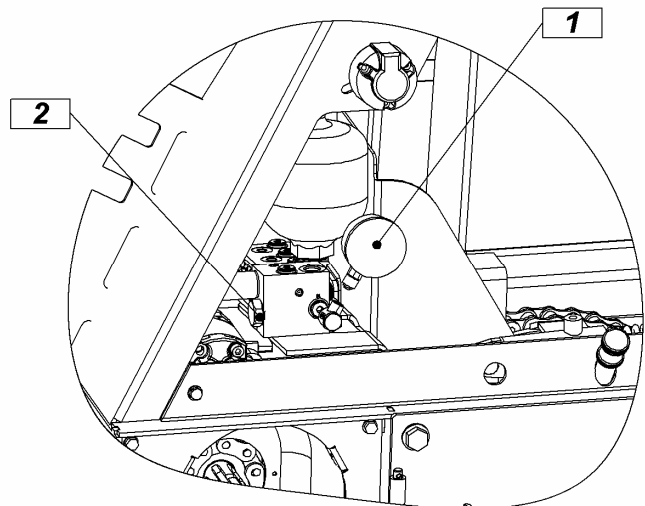

Figure 14

## REMOVAL OF FAULTS

<b>Determined fault (malfunctions)</b>	<b>Cause</b>	<b>Procedure for removal of faults (malfunctions)</b>
<b>Manometer does not show pressure.</b>	Manometer does not work.	Replace the manometer.
	Sprocket does not drive the pump (broken axle, broken chains, spring pin on the sprocket).	Replace the damaged part.
	Impurities in pressure valve.	Unscrew the valve, clean it and replace it.
	Folded tube.	Replace the tube.
	Not enough oil in the tank.	Fill up oil in the tank.
	Pump malfunction.	Replace the pump.
<b>Pressure drops too quickly.</b>	The battery's membrane is damaged or nitrogen level in the battery is incorrect.	Fill up nitrogen or replace the battery.
	Impurities in steering valve.	Unscrew the valve, clean it and replace it.
	Non-return valve does not seal (impurities or malfunction).	Unscrew the valve, clean it and replace it.
	Pressure valve does not seal (impurities or malfunction).	Unscrew the valve, clean it and replace it or change it.
<b>Clutch cannot be engaged.</b>	Impurities in steering valve.	Unscrew the valve, clean it and replace it.
	No voltage / electrical current on the electro-magnetic coil.	Check the electrical wiring and contacts.
	Insufficient voltage on the electro-magnetic valve (min 11.6 V).	Check the electrical installation on the tractor.
	Electro-magnetic coil does not work.	Change the electromagnetic coil.
<b>Brake cannot be engaged.</b>	Impurities in steering valve.	Unscrew the valve, clean it and replace it.
	No voltage / electrical current on the electro-magnetic coil.	Check the electrical wiring and contacts.
	Insufficient voltage on the electro-magnetic valve (min 11.6 V).	Check the electrical installation on the tractor.
	Electro-magnetic coil does not work.	Change the electromagnetic coil.

<b>Determined fault (malfunctions)</b>	<b>Cause</b>	<b>Procedure for removal of faults (malfunctions)</b>
<b>Pressure oscillates.</b>	With each engagement of electromagnetic valve it is normal for the pressure to oscillate. If the pressure oscillates, when the valves are not engaging, this means that the pressure valve is damaged or there are impurities in the valve.	Change or clean the pressure valve.
<b>Insufficient pulling force.</b>	Grease on frictional padding of the clutch.	Replace clutches.
	Burnt frictional padding of the clutch.	Clean padding with sandpaper or grind (thickness approximately 0.5 mm).
	Insufficient pressure in hydraulic system (required pressure at least 140 bar).	Determine the reason for pressure drop.
	Worn frictional padding of the clutch.	Replace clutches.
	Incorrectly installed clutch.	Install according to technical documentation.
<b>Insufficient brake force.</b>	Improper setting.	Setting according to instructions for use.
	Grease on the padding of the brake belt.	Replace the brake belt.
	Damaged brake belt.	Replace the brake belt.
	Damaged brake mechanism.	Replace damaged parts.
<b>Wire rope cannot be pulled out or the pulling is difficult.</b>	Improper setting of pre-brake.	Setting according to instructions.
	Improper setting of brake.	Setting according to instructions.
	Damaged or stuck wire rope.	Pull out the rope with a tractor and, if required, install a new wire rope.
	Damaged brake belt.	Replace the brake belt.

<b>Determined fault (malfunctions)</b>	<b>Cause</b>	<b>Procedure for removal of faults (malfunctions)</b>
<b>The winch pulls, despite the clutch being disengaged.</b>	Error on electro-magnetic valve.	Cease work immediately and consult a service company.
	Not enough clutch distance.	Setting according to instructions.
	Broken part of frictional padding on the clutch.	Replace clutches.
	Excessively tensioned drive chain.	Chain setting according to instructions
	Damaged winch drum.	Replacement or repair of the drum.

## A LIST OF REPLACEMENT PARTS

### Forestry winches – 65H, 65Hpro, 85H, 85Hpro (*Figure 1*)

Position	Name	Design or standard number			
		65H, 65Hpro		85H, 85Hpro	
		No. of pieces		No. of pieces	
1	Framework	1	7002.01.00.0	1	7004.01.00.0
2	Small cover	1	502.11.09.0	1	502.11.09.0
3	Cover	1	702.38.02.0	1	702.38.02.0
4	Shaft holder	1	502.11.08.0	1	502.11.08.0
5	Spacer 1	1	7002.06.12.0	1	7002.06.12.0
6	Braking belt	1	702.61.00.0	1	704.61.00.0
7	Bearing 6310 2Z	5	DIN 628	5	DIN 628
8	Rope drum	1	7002.05.00.0	1	7004.05.00.0
9	Freewheel spring	1	702.70.00.0	1	702.70.00.0
10	Clutch 1	1	702.23.00.0	1	702.23.00.0
11	Clutch 2	1	702.22.00.0	1	702.22.00.0
12	Large freewheel z = 54	1	7002.06.01.0	1	7004.06.01.0
13	Drum shaft	1	7002.06.00.0	1	7004.06.07.0
14	Connection	1	5006.12.00.0	1	5006.12.00.0
15	Connection guard	1	7002.00.20.0	1	7002.00.20.0
16	Connection pin	1	702.56.03.0	1	702.56.03.0
17	Adjusting screw	1	5006.05.37.0	1	5006.05.37.0
18	Protective nut	1	5006.05.38.0	1	5006.05.38.0
19	Pressure spring	1	5006.05.36.0	1	5006.05.36.0
20	Pin Ø14	1	5006.05.34.0	1	5006.05.34.0
21	Hydraulics protection	1	7002.00.65.0	1	7004.00.65.0
22	Safety net	1	7006.88.00.0	1	7006.88.00.0
23	Safety net - small	1	7002.00.65.0	1	7002.00.65.0
24	Foot	2	7002.10.00.A	2	7002.10.00.A

Position	Name	Design or standard number			
		65H, 65Hpro		85H, 85Hpro	
		No. of pieces		No. of pieces	
25	Foot cork	2	5006.00.16.0	2	5006.00.16.0
26	Holder	2	5006.00.15.0	2	5006.00.15.0
27	Pressure spring	2	5006.00.18.0	2	5006.00.18.0
28	Adapter 17	2	5006.05.22.0	1	702.42.00.0
29	Long nut M14	1	7002.05.24.0	1	7002.05.24.0
30	Breaking belt plate	1	7002.05.13.0	1	7002.05.13.0
31	U holder	1	7002.05.16.0	1	7002.05.16.0
32	Breaking belt roller	1	7002.05.14.0	1	7002.05.14.0
33	Tensioning screw	1	7002.05.23.0	1	7002.05.23.0
34	Breaking belt pin	1	/	1	/
35	Breaking belt plate	2	7002.05.12.0	2	7002.05.12.0
36	Spring pin 3 x 20	1	DIN 1481	1	DIN 1481
37	Spring pin 6 x 30	6	DIN 1481	6	DIN 1481
38	Cotter 5 x 50	2	DIN 94	2	DIN 94
39	Spring fuse 10 + chain	2	DIN 914	2	DIN 914
40	Greaser M8	1	DIN 71412	1	DIN 71412
41	Screw M12 x 40	1	DIN 933	1	DIN 933
42	Nut M12	3	DIN 934	3	DIN 934
43	Screw M8 x 16	21	DIN 933	21	DIN 933
44	Washer M8	21	DIN 125	21	DIN 125
45	Washer M14	4	BN 13291	4	BN 13291
46	Screw M14 x 30	3	DIN 933	3	DIN 933
47	Screw M14 x 25	1	DIN 933	1	DIN 933
48	Nut M50	1	DIN 934	1	DIN 934
49	Nut M50	1	DIN 439	1	DIN 439
50	Screw M10 x 70	2	DIN 933	2	DIN 933
51	Screw M12 x 50	2	DIN 933	2	DIN 933
52	Pressure spring	1	5006.05.36.0	1	5006.05.36.0
53	Nut M12	3	DIN 985	3	DIN 985
54	Washer M8	9	DIN 9021	9	DIN 9021
55	Screw M12 x 65	1	DIN 933	1	DIN 933
56	Screw M12 x 45	2	DIN 933	2	DIN 933
57	Washer M10	1	DIN 125	1	DIN 125
58	Nut M8	9	DIN 985	9	DIN 985
59	Spring pin 4 x 16	1	DIN 1481	1	DIN 1481
60	Guard L	1	7002.01.46.0	1	7002.01.46.0
61	Guard R	1	7002.01.45.0	1	7002.01.45.0

65H, 65Hpro, 85H, 85Hpro

-1-

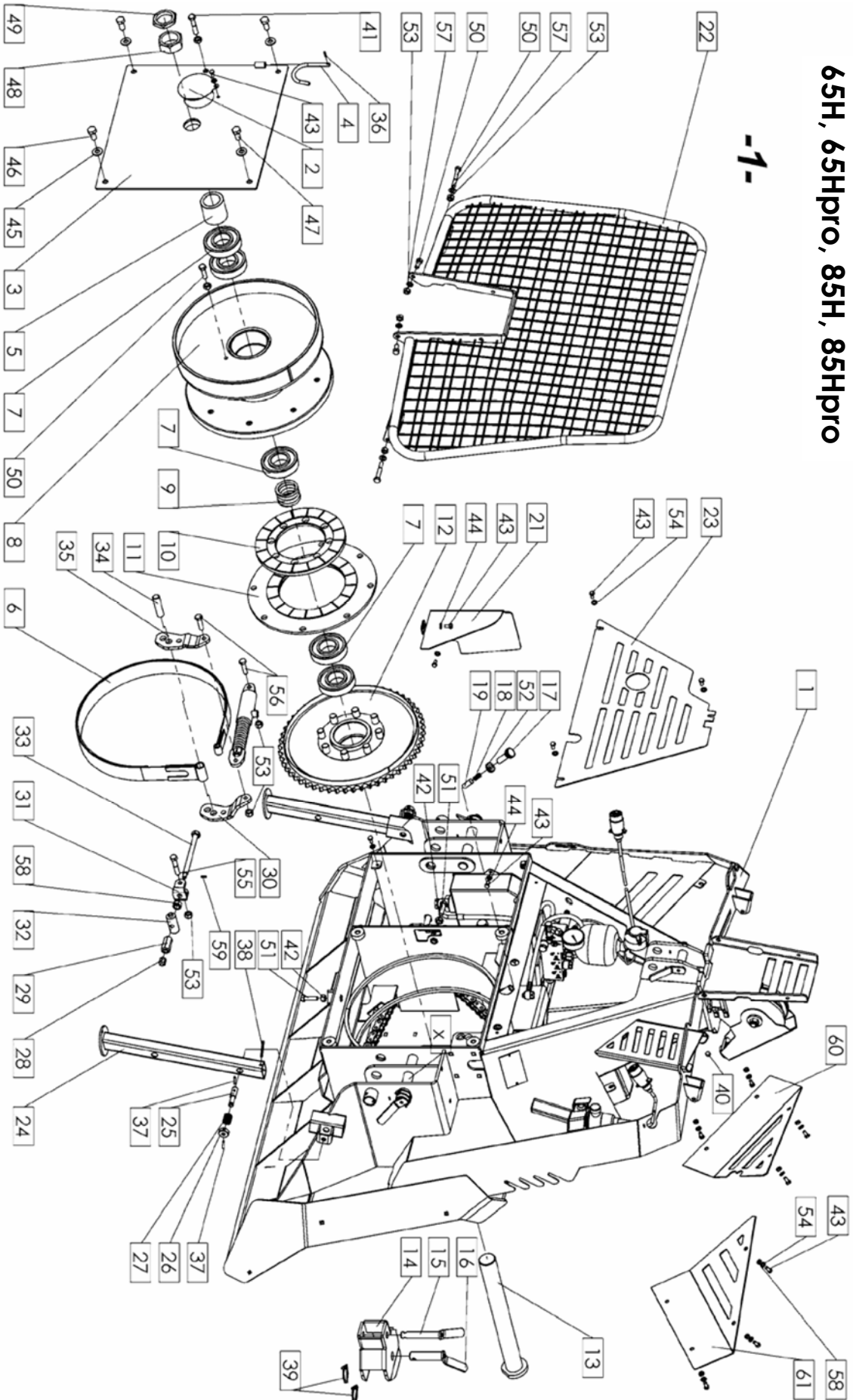



**A LIST OF REPLACEMENT PARTS**  
**Forestry winches – 65H, 65Hpro, 85H, 85Hpro (Figure 2)**

Position	Name	Design or standard number			
		65H, 65Hpro		85H, 85Hpro	
		No. of pieces		No. of pieces	
1	Lower pulley housing	1	7002.26.01.A	1	5006.10.01.0
2	Protective pin of the lower pulley	1	7002.26.08.0	1	5006.10.09.0
3	Lower pulley pin	1	7002.26.07.A	1	502.10.10.0
4	Lower pulley axis	1	702.26.22.0	1	5006.10.18.A
5	Bearing 6207 2RS	2	DIN 628	2	DIN 628
6	Pulley wheel	1	702.25.10.0	1	502.09.08.0
7	Lower pulley	1	7002.26.00.0	1	5006.10.00.0
8	Upper pin	1	702.56.03.0	1	5006.09.00.0
9	Snap ring	1	DIN 983	1	DIN 983
10	Guide sleeve	1	5006.09.12.0		5006.09.12.0
11	Lower pin	2	702.56.00.0	2	502.00.20.0
12	Rivet 5mm	4	DIN 7337	4	DIN 7337
13	Shaft guard	1	502.35.02.0	1	502.35.02.0
14	Drive cover	1	7002.00.61.0	1	5006.00.61.0
15	Chain 1" 16B1	1	DIN 8187	1	DIN 8187
16	Master link 1" 16B1	1	DIN 8187	1	DIN 8187
17	Chain with a freewheel z = 22	1	702.28.01.0	1	5006.08.20.0
18	Dowel A 12 x 8 x 28	2	DIN 6885	2	DIN 6885
19	Bearing 6308 2ZR	4	DIN 628	4	DIN 628
20	Lower drive housing	1	702.28.10.0	1	5006.08.15.0
21	Freewheel	1	702.28.03.0	1	702.28.03.0
22	Protective washer MB 8	2	DIN 5406	2	DIN 5406
23	Nut KM/8 M40 x 1,5	2	DIN 981	2	DIN 981
24	Entire lower drive	1	702.28.00.0	1	5006.08.10.0
25	Longer chain	1	DIN 8187	1	DIN 8187
26	Master link	1	DIN 8187	1	DIN 8187
27	Drive shaft	1	7002.08.65.0	1	7002.08.65.0
28	Vent	1	Mintor	1	Mintor
29	Sealing cover	1	DIN 3780	1	DIN 3780
30	Upper drive housing	1	7002.08.57.0	1	7002.08.57.0
31	Entire upper drive	1	7002.08.40.A	1	7002.08.40.A
32	Pinion 1	1	7002.08.61.0	1	7002.08.61.0
33	Pinion 2	1	7002.08.62.0	1	7002.08.62.0
34	Pinion axis 2	1	7002.08.64.0	1	7002.08.64.0
35	Pinion 3	1	7002.08.63.0	1	7002.08.63.0
36	Upper pulley housing	1	7002.25.01.0	1	7004.25.01.0
37	Upper pulley reinforcement	/	/	1	704.00.20.A

Position	Name	Design or standard number			
		65H, 65Hpro		85H, 85Hpro	
		No. of pieces		No. of pieces	
38	Upper pulley axis	1	7002.25.26.0	1	7002.25.26.0
39	Upper pulley spacer	2	7002.25.09.0	2	7002.25.09.0
40	Upper pulley wire rope guide	1	7002.25.17.0	1	7004.25.17.0
41	Upper pulley	1	7002.25.00.0	1	7004.25.00.0
42	Spring pin 8 x 50	2	DIN 1481	2	DIN 1481
43	Spring pin 6 x 45	1	DIN 1481	1	DIN 1481
44	Pin holder	1	5006.10.10.0	1	5006.10.10.0
45	Spring fuse 10 + chain	1	DIN 914	1	DIN 914
46	Spring fuse 8 + chain	2	DIN 914	2	DIN 914
47	Guard	2	5006.10.11.0	2	5006.10.11.0
48	Spring pin 6 x 15	2	DIN 1481	2	DIN 1481
49	Screw M12	1	DIN 906	1	DIN 906
50	Spring	1	5006.10.12.0	1	5006.10.12.0
51	Washer M8	11	DIN 125	11	DIN 125
52					
53					
54	Nut M12	7	DIN 985	7	DIN 985
55	Washer M12	16	DIN 7349	16	DIN 7349
56	Screw M12 x 110	3	DIN 931	3	DIN 931
57	Nut M16	2	DIN 934	2	DIN 934
58	Screw M16 x 55	1	DIN 933	1	DIN 933
59	Screw M16 x 100	1	DIN 933	1	DIN 933
60	Screw M5 x 10	1	ISO 4762	1	ISO 4762
61	Screw M12 x 80	2	ISO 4762	2	ISO 4762
62	Screw M12 x 50	2	DIN 931	2	DIN 931
63	Washer M12	2	DIN 125	2	DIN 125
64	Magnet	1	/	1	/
65	Greaser M8	1	DIN 71412	1	DIN 71412
66	Bearing 6002	3	DIN 628	3	DIN 628
67	Washer	1	7002.08.67.0	1	7002.08.67.0
68	Washer	1	DIN 988	1	DIN 988
69	Sealing cover	1	DIN 3780	1	DIN 3780
70	Screw M8 x 16	3	DIN 933	3	DIN 933
71	Screw M14 x 50	/	/	2	DIN 933
72	Washer M14	/	/	2	DIN 125
73	Washer 35	4	DIN 988	4	DIN 988



**A LIST OF HYDRAULIC REPLACEMENT PARTS**  
**Forestry winches 65H, 65Hpro, 85H, 85Hpro (Figure H)**

<b>Position</b>	<b>Name</b>	<b>No. of pieces</b>	<b>Number</b>	<b>Notes</b>
H1	Hydraulic hose	1		
H2	Hydraulic hose	1		
H3	Hydraulic hose	1		
H4	Hydraulic hose	1		
H5	Hydraulic hose	1		
H6	High pressure filter	1		
H7	Safety valve	1		
H8	Angular connector	1		
H9	Hydraulic plug 1/4"	1		
H10	Hydraulic manometer connection	1		
H11	Hydraulic bolt – through 1/4"	3		
H12	Hydraulic bolt – through 3/8"	3		
H13	Cu washer 1/4"	6		
H14	Cu washer 3/8"	6		
H15	Hydraulic pump	1		
H16	Hydraulic brake cylinder	1		
H17	Hydraulic clutch cylinder	1		
H18	Hydraulic block	1		
H19	Reservoir	1		
H20	Reservoir cover TCL S3G 1/2"	1		
H21	Suction filter 1/4" 90µm	1		
H22	Hydraulic membrane accumulator 75	1		
H23	Manometer	1		
H24	Gasket set	1		
H25	Coil	2		
H26	Electromagnetic valve	2		
H27	Safety valve	1		
H28	7-pin socket aluminium	1		
H29	Hydraulic connection 1/4" / 16	2		
H30	Hydraulic connection 1/4" 1/4"	1		
H31	Hydraulic extension 1/4" 1/4"	1		

Position	Name	No. of pieces	Number	Notes
H32	Hydraulic connection 1/2" x 1/2"	1		
H33	Reservoir cover gasket	1		
H34	Cu washer 21x26x1.5	2		
H35	Cu washer 36x42x2	1		
H36	Plug	2		
H37	Connector	2		
H38	Steering console	1		
H39	Cylinder spring	1		
H40	Cu washer 14x18/20	1		
H41	Hydraulic connection 1/4" / 14	1		
H42	Hydraulic connection 3/8" x 1/4"	1		
H43	Hydraulic connection 3/8" / 16	1		
H44	Hydraulic connection M36x1,5 3/8"	1		



# REMOTE CONTROL UNIFORMEST

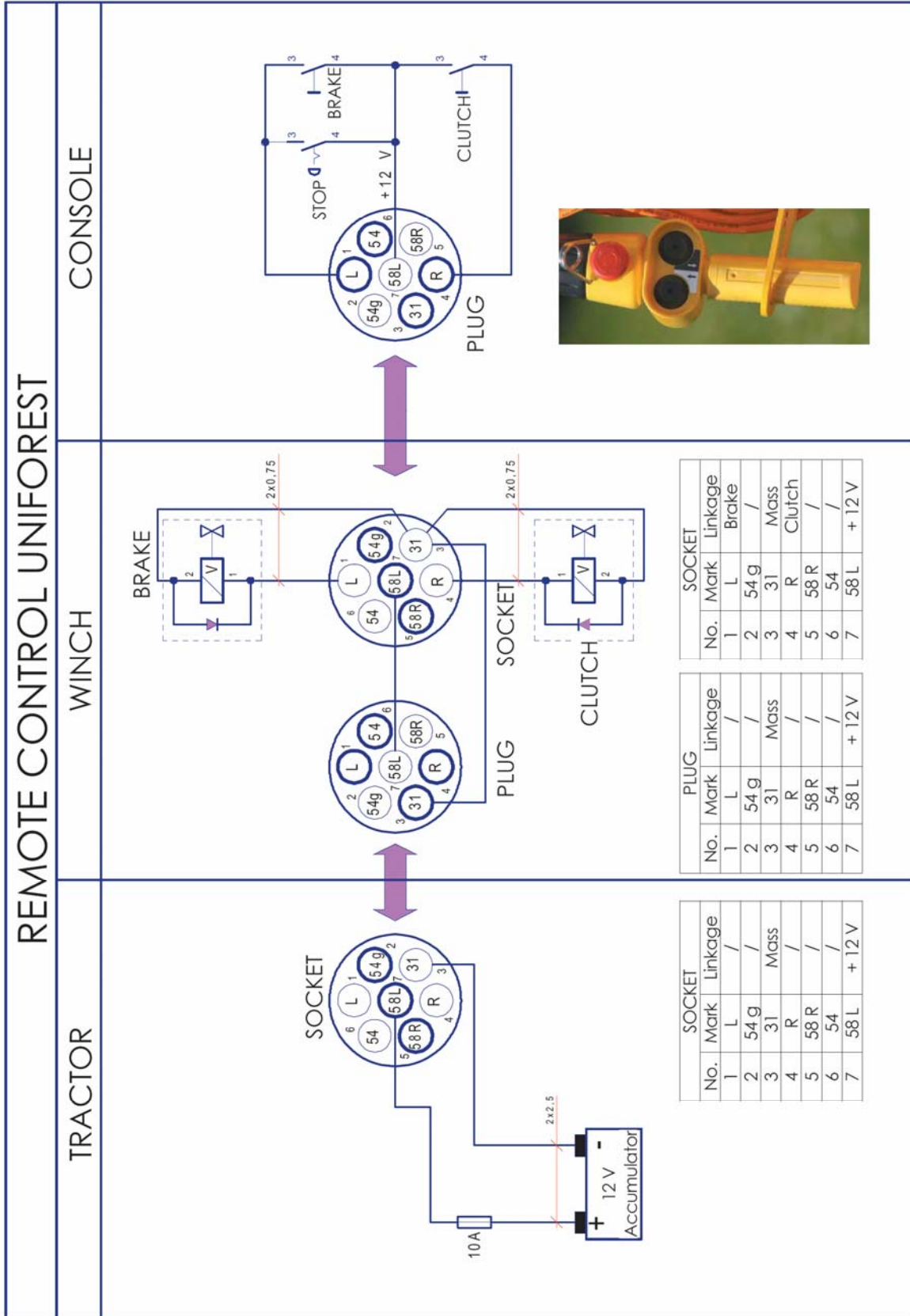

## **EC – Declaration of conformity**

In accordance with EC guideline 2006/42/EC and  
Regulation on machine safety (Ur.list RS, št.75/08)

we

**UNIFOREST** d.o.o.

Dobriša vas 14, 3301 PETROVČE, SLOVENIA

Marko Polak, BE, Uniforest, Dobriša vas 14, 3301 PETROVČE

declare with full responsibility that the following product:

**Winch:**

**UNIFOREST 45H, 55H, 55Hpro, 65H, 65Hpro, 85H, 85Hpro**

meets the basic safety and health requirements of EC guideline 2006/42/EC  
and Regulation on machine safety (Ur.list RS, št.75/08)

For appropriate enforcement of relevant safety and health requirements  
of EC guidelines, the following standards and/or technical regulations were  
applied:

EN ISO 12100/2010 EN ISO 4254-1/2010/ AC:2011  
EN ISO 13857/2008 EN ISO 4413/2010 ÖNORM L5276/ 2008

Petrovče, 05.04. 2012

Drago Pintar, BE  
**UNIFOREST**  
d.o.o. 1  
Dobriša vas 14, SI-3301 PETROVČE