



WWW.HUD-SON.COM • 800.765.SAWS



PATRIOT SAWMILL OPERATOR'S MANUAL

8201 STATE ROUTE 12 • PO BOX 345 • BARNEVELD NY 13304

A N O T E F R O M H U D - S O N

Thank you for your purchase of a sawmill from Hud-Son Forest Equipment. We are pleased that you chose us as your supplier of your forestry equipment.

Hud-Son Forest Equipment has been in the forestry business since 1965 and prides itself on developing new and innovative products for the forestry business. Our product line is always transforming so please check us out on the web at www.hud-son.com for the up and coming developments we are making.

Should you have any questions with the setup of your mill or have any technical questions please feel free to contact our on-site technician Monday - Friday, 8 to 4:30 and Saturdays from 8 to noon eastern time at 800-765-7297. We are always available to our customers for any questions or concerns they may have about their equipment.

C O N T E N T S

2A note from Hud-Son
3Introduction
4Safety
6Set Up
10Log Setup & Cutting
15Component Parts Identification
19Care & Maintenance
21Preventative Maintenance Check List
22Trouble Shooting
24Parts & Warranty
30Sawmill Drawings -attached separate
31..... Parts List for Sheave and clutch

INTRODUCTION

Purchaser Agreement

By accepting the delivery of your sawmill by Hud-Son Forest Equipment you agree that you will not modify your mill from it's original assembly. This will VOID any warranty from Hud-Son Forest Equipment.

Please fill out the information for quick reference:

Dealer: _____
Phone Number: _____
Address: _____

Purchase Date: _____
Model: _____
Serial Number: _____

This manual is filled with the latest information and specifications at the time of publication. We have the right to make changes as they are needed. Any of the changes in our product may cause a variation between the illustrations and explanations in the manual and the item that you have purchased.

DISPUTES

All disputes, claims and causes of action arising out of the delivery, use, or warranty claims for personal injury and or property damage must:

1. Claimant must provide a written notice of the claim or dispute to the company (at the address below) at least 30 days after the claim arose prior to commencement of any action;
2. Company has 60 days to make a decision on the claim and will provide a written response to claimant;
3. No action may be commenced until after the company has provided its decision on the claim;
4. All claims against the company for any cause related to delivery, design defects, repairs, use of the equipment or warranty shall

be filed in Supreme Court, Oneida County, State of New York. The parties may file for Arbitration in Oneida County New York after consent by both parties.

5. Construction and interpretation of this agreement and any and all claims shall be subject to the Laws of the State of New York.

6: The address for submission of claims is:

Hud-Son Forest Equipment
PO Box 345
8201 State Route 12
Barneveld, NY 13304

7. Notices under this agreement must be in writing and sent by certified or registered mail.

Safety Guidelines

The reason for the safety section is to inform the operators and maintenance personnel, the precautions that should be taken while operating or servicing the Hud-Son Mills. Please use good judgement and keep safety in mind when operating Hud-Son machinery. Please read and follow ALL the instructions in this manual before operating the Hud-Son Mill safely at all times. These instructions were produced for your benefit. Your ability to understand and follow the instructions is essential for the safe operation of this product. Always call your servicing dealer if you are in doubt before operation of any kind.

General Safety Procedures

1 - Always wear safety glasses, ear protection, and gloves while operating or servicing the machine.



- 2 - Keep all body parts and foreign objects away from all moving parts. Do not reach into the machine while it is still operating. (Be Sure The Machine Is OFF.)
- 3 - Do not attempt to override any safety features on the machine.
- 4 - Inspect the machine before every use for wear, damage, and that it's functioning correctly. If the machine has been damaged or is not running correctly. DO NOT attempt to operate the machine. Repair or replace all parts when necessary.
- 5 - Do not wear loose clothing or jewelry while operating or servicing the machine.
- 6 - All replacement parts should be of the same specifications as the original parts on your Hud-Son machine.
- 7 - All guards and covers must be in place before operating the machine.
- 8 - Before starting the machine be sure that it is set up properly.
- 9 - DO NOT operate or service any machinery while under the influence of drugs or alcohol, while tired or if you are unable to control your movements.
- 10 - All worn or damaged Decal's should be replaced.
- 11 - Any modifications to the machine requires written approval from Hud-Son Forest Equipment.
- 12 -The sawmill should only be used when it is on level stable ground.

The safety rules are made for the benefit of the persons operating and servicing the machine, to prevent injury to oneself or others. Please review all setup and operating procedures before attempting to run the machine, whether covered in this manual or not, to ensure the safest operation of this product.

CAUTION

Before, During and After Operation



Check the engine compartment for sawdust and wood trash build up in and around the engine compartment and the exhaust area to prevent any possible fires from starting due to excessive build up. Always clean the sawdust out from under the machine after shut down and be sure there is no sawdust build up near or around the muffler area.

Hud-Son Forest Equipment is not liable for damage to property or personal injury due to the failure of any person and/or operator to follow the instructions and recommendations set forth in this manual or any other instructions or recommendations contained in other literature issued by other vendor manuals in the owner's kit.

Product Safety Decal's

The Decal's below are used on the Hud-Son Saw Mills to identify warnings and prohibited actions. It is very important that you understand the meaning of the Decal's for your safety and the safety of others. Decal's are to be replaced if worn or illegible.

<p>CAUTION - Be EXTRA careful around these areas, unsafe practices may cause personnel injury or damage.</p>	<p>BLADE LUBE TANK - Be sure to use the correct lubrication, if incorrect lube is used it may cause personnel injury or damage.</p>
<p>DANGER - Be careful around any rotating parts, they may cause personnel injury or damage.</p>	<p>NOTICE - Please remember to send in warranty card and information.</p>
<p>DANGER - Be sure to be very cautious and alert, these areas may cause personnel injury or damage.</p>	<p>CAUTION - All debris need to be removed from machine before transporting, failure to do so may cause personnel injury or damage.</p>
<p>CAUTION - Operating equipment without guards may cause personnel injury or damage.</p>	<p>CAUTION FIRE HAZARD - Keep all sawdust away from motor.</p>



Receiving and Unit Inspection

- 1 - Upon receiving your unit do a walk around and visual inspection of the unit. Make note of any damage and contact us immediately with any issue you may have.

Unpacking Unit

- 1 - Flat bed trailer delivery: remove straps or chains securing the unit.
- 2 - Remove lag screws and or strapping that secures the machine to the skid.

Set-Up and Operation After Completion of Assembly Instructions

Moving the Unit

(Forklift is needed for track units)

- 1 - Machine needs to be lifted at the lift point, see picture for points.
 - a. Use a safety device for lifting to avoid any damage/injury.
- 2 - Move unit to operator's site, lower unit and remove unit from forks.



Ground Track Set Up For the Patriot Sawmill

Steps for Setting Up the Hud-Son Saw Mill

A. Machine Set-Up (ground track unit) (SEE FIG A page #7)

- 1 - For best results and easier set-up, the mill location should be level solid ground and free of obstructions.
- 2 - A level cement pad is the best option, but square timbers also work well. You will need to support the track at each joint and under each cross member of the track .
- 3 - You will need to be sure that the mill TRACK is level from front to back and side to side. The better the mill track is supported the better the mill will work.
- 4 - There should be a 4 ft. clear work area around the entire mill.

B. Welded Track Assembly

- 1 - Dogs need to be facing in the same direction, all the movable dogs need to be on the operators side of track.
- 2 - There are additional holes in the track so that the dogs can be moved to different positions for cutting shorter or longer logs if needed.
- 3 - The tracks are bolted together using the 1/2" bolts and nuts provided. The mill track will have 2 bolts/2nuts per section of track. Line up the tracks so that the holes align. Using the provided bolts, put them through the holes and finger tighten the nuts. Adjust the track height so that the 2 pieces of track meet flush and level. Work one side then the other, once level has been achieved, check the track to see if it aligns vertically at the joint. If the track is not aligned correctly use a hammer to tap it into position. Do not tap on the vertical rail. Once this is accomplished tighten the bolts securely. NOTE: when the mill head rolls over the track joint it should be smooth. There should be no bump or rise at the track joint. (see fig. B page #7)

4 - The track comes with four yellow track stop tabs and the bolts to fasten them to the track. Place the track stops at the four end corners, then bolt on the inside of the track. Place them on the inside corner of the track, secure them into place with the bolt and nut provided. The track stop tabs are placed at an angle over the track to prevent the mill head from rolling off the track at each end . (see fig. C)

Moveable dogs on one side

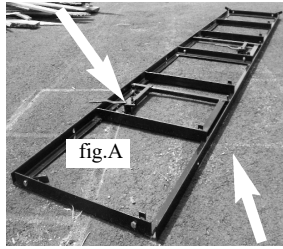

Track on level ground, free of obstructions

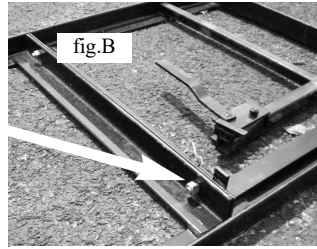

*Bolted together Track
Flush & Level*

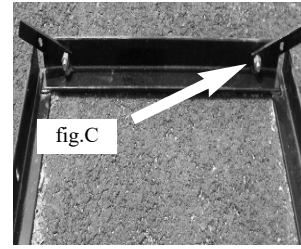

Track Stops

5 - To saw a board accurately, the track needs to be straight and flat. To obtain this, use a string tied tight from end to end or a level. If the track/trailer has a crown or dip, you will not be able to saw a straight board. (see fig.D below.)

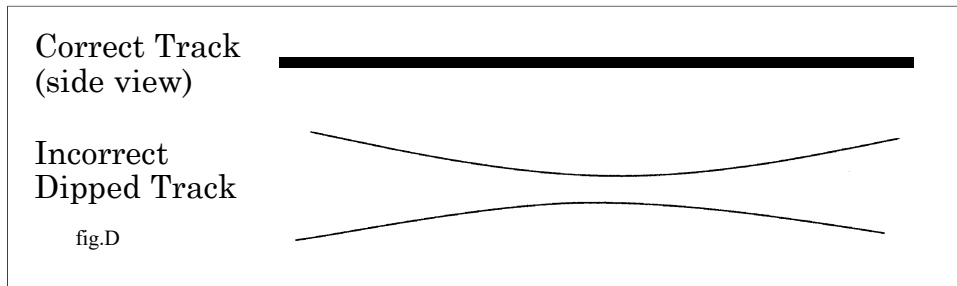

Correct Track Set-Up / Layout

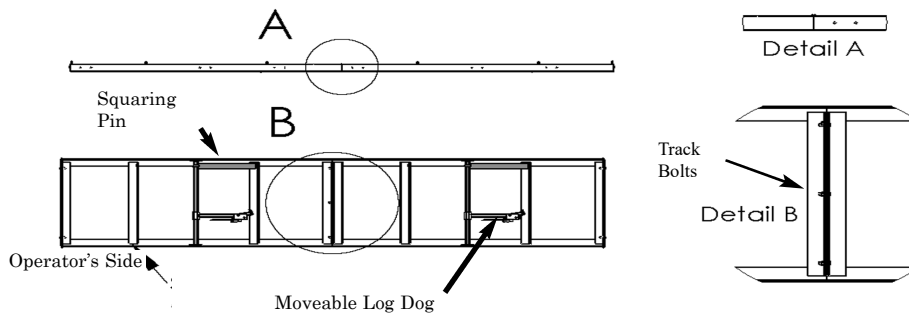

Correct Track Set-up

NOTE : If you set up on soft or frozen ground it's best to check the track daily for levelness due to changing weather and temperature.

C. Setting Head on Track, Ground Models

Once your track is level, you are ready to set the head on the track. Once again, be sure the area is still free and clear of obstructions. You will want the head to roll freely down the track.

- 1 - Install the head with operator's side on the same side as the moveable dog.
The discharge side is the side with the squaring pins.
- 2 - Raise the head 3 inches and roll from one end to the other. The head should roll smoothly along the track. If the head "thumps" when it passes over the track joint, check to make sure the tracks are level. Re-level the track and try rolling the head again. Also be sure to watch the track as you roll the head, if the track moves down or up you will need to use shims to support the track in that area.

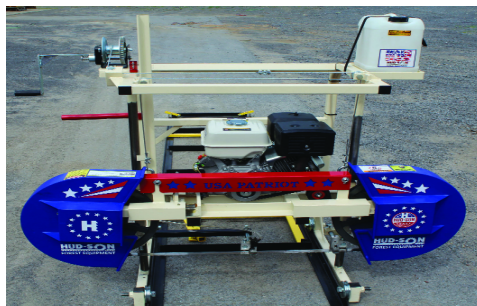

Correct head placement; Operators side is on side with the scale stick and hand winch.

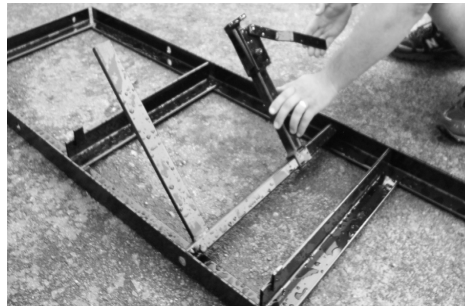

Squaring arm on left adjustable dog on right.

D. Tensioning the Blade on all Models

NEVER tension your blade with the engine running. If there is tension left on the blade for a period of time, it can cause flat spots on the band wheel belt. This can cause vibration and the blade to fall off the wheel. Always remember to de-tension your blade when you are done sawing for the day.

- 1 - For all of our mills, make sure blade is flush with the back of the band wheel or shive
- 2 - To tension or loosen the blade, (see figure G. on page #9)
- 3 - Turn the adjusting nut, clockwise until 30-35 pounds of torque is achieved.
The recommended tool for this is a torque wrench. By hand, rotate blade 3-4 full revolutions; this centers the blade on the wheels.
- 4 - With gloves on, pull up on the blade at the center guard. Allow for no more than a 1/4" movement up or down on the blade.
- 5 - Check that guides are not so tight they cause the blade to heat up.
If this occurs readjust guides.
- 6 - Perform a simple test call the "Flutter" test. Put the guards on and then run the engine at full RPM's (be sure the blade is not in a cut during this test) and watch the blade under the blade guard. The blade must run straight, if it does not, shut the engine down and apply more tension. Keep in mind that over tensioning will also cause the blade to flutter. You should have attained proper tension around 30-35 pounds.
- 7- A tensioned blade should come off the bottom of the band wheel and run straight across to the other band wheel, so there is NO sag in the blade between the two wheels.

**Before operating the Hud-Son Saw Mill
the following checks and services need to be performed daily:**

Lubricate Grease Fittings and Oil Points (see Diagram for locations)	✓		
Clean Battery Connections (if applicable)	✓		
Check Wiring and Connections for Corrosion and Decay	✓		
Check Blade Sharpness and set proper tension	✓		
Fuel - fill as needed [non ethanol gasoline] and check engine oil	✓		
Blade Lubricant - fill as needed with water/ pinesol mix	✓		
Check belts (chaffing, dry rot, cracks, replace when worn out / hoses if applicable)	✓		

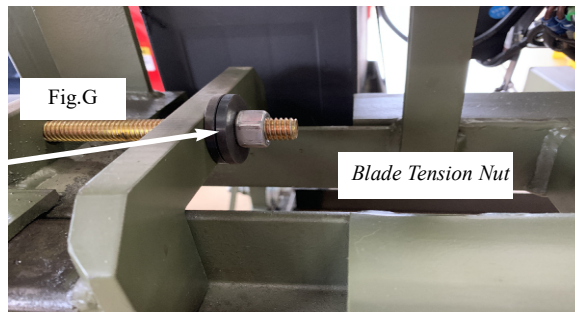

Grease the Blade Tension thrust bearing between the (2) cupped washers .

Keep threads clean and lubed. Blade tension bolt 30-35 ft lbs. torque.

Blade Lubrication

Do NOT use: petroleum products, petroleum based products, flammable products, or a vegetable oil based product. The above products mixed with water or straight will cause damage to your mill. The fluid will be slippery between the blade and wheel belting and could cause the blade to come off.

Do use: In the summer months use tap water. with 1 oz of dish soap or pinesol added per gallon of water. This will help keep the blade clean, reduce heat and prevent pitch build up on the blade,

In the winter months water will freeze in the lube tank. Use regular windshield washer fluid (usually blue in color) If there is a pitch build up problem add 1 oz. of dish soap or pinesol.

Adjustment: Before starting the engine adjust the flow of lube to the blade by adjusting the flow shut off valve so there is a constant drip. If more lube is necessary continue to adjust the valve until desired flow is acquired.

Log Set-Up

F. Setting Logs

Once the track is set, the head is in place and the blade is tensioned correctly, you are almost ready to cut. (Note: Always try to start your cut from the small end to the larger end of a log.)

- 1 - Place the log determined by the mill size, on the center of the track. Using the log dogs secure the log to the track. Be sure to dog the log high enough (1/2" way up the log) to ensure the log does not move. If the log is too big for the log dog to hold in place, but your sawmill head still rolls unobstructed use blocking and wedge it under the log to hold it from rolling during the cut.

NOTE: Do not over dog the log, This will cause the log or cant to twist, you only need enough pressure to hold it flat and secure against the squaring pins.



Squaring Arm and Adjustable Dog

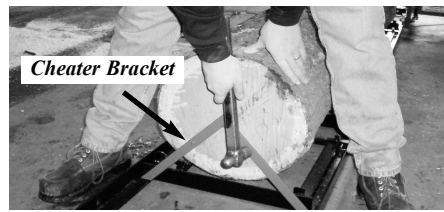

If log is too big for the log dog, use the "Cheater" to hold log

G. Getting Ready to Cut

Now is the time to debark or clean your log. This can be achieved by the simple chain-saw attachment, called a Log Debarker (*available through Hud-Son Forest Equipment Inc.*) or you can pressure wash or use whatever method available to remove any mud or bark from the logs. By debarking and cleaning your log it will extend the life of your blade significantly. (see fig F-1)

- 1 - Adjust the Hud-Son guides so that they are slightly (no more than 2 inches) wider than the maximum width of the log. (see Fig F-2)

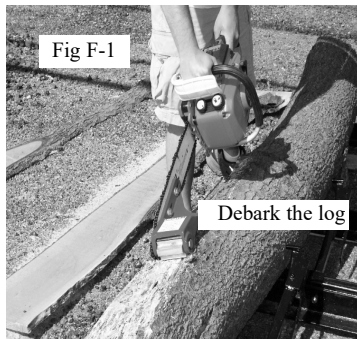

Fig F-1

Debark the log

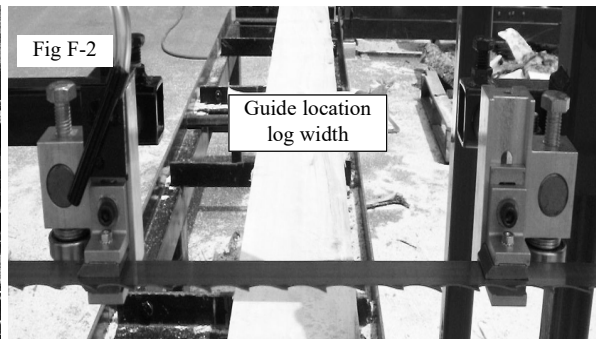

Fig F-2

Guide location
log width

Start Engine Procedure

- 1 - With the fuel on, set throttle to start position, choke if necessary, turn switch to on to start engine. For Summer Use: Be sure to let the unit idle for at least 5 minutes before any use.
- 2 - Winter Use: Be sure to let the unit idle for at least 10-15 minutes before any use.
- 3 - If the unit has been sitting for a period of time, allow the unit to run long enough to warm up good .

Cutting Procedure

(**Note:** as you cut slabs, boards or squares you may need to adjust the guide to ensure the best performance and quality cuts)

- 2 - Find the top of the log with the blade. Remember, that you may have cheaters in place so be sure these are clear when making the first cut. You will be removing the top portion of the log. (top slab)
- 3 - With the manual lift models, crank your head down to just past the desired height mark and then crank up to the height mark for the next cut, this ensures that the head is set equal on both sides. Make sure your blade will clear your log dog assembly.
- 4 - Start your engine. (Refer to the engine manual for proper engine maintenance)
- 5 - With the engine at idle position, increase the throttle to full speed to engage the blade. Sawing should always be done with the engine at Full Throttle. Start the blade in the log slowly, DO NOT ram it into the log!
- 6 - Once started in the log gently push the saw head through the log, pushing on the head frame. If the engine starts to labor, you are going too fast, slow down. Go slow through burls and knots as the engine may bog down through these parts of a log.
- 7 - When you are at the end of the log, power down the engine, crank the head up so that it will clear the log and roll mill head back to the front of the log. For ease of operation, put the slabs on the operator's side of the mill, this way you will not have to dig through sawdust for your lumber.
- 8 - You now have a flat surface on top of your log, remove the cheaters (if applicable) you will no longer need them, as long as the log dogs will hold the log in place.
- 9 - Raise the log dog assembly so that they are standing in the track. Turn the cut side of the log, using a cant hook, $\frac{1}{4}$ of a turn. The flat side must be flush against the squaring pin to assure a square cant. (see fig. G Page #13)
- 10 - Adjust the log dog at an angle to the track so that the blade can pass over the top, but so that the dogs are effective in securing the log. (see Fig. G and G-1, page 12)
- 11 - Once again, increase the engine throttle to start the blade, and saw another slab off. You will repeat these steps until your log is squared into a cant. Once you have obtained the dimension you need to make lumber, then start sawing your dimensional lumber.
- 12 - NOTE: All logs have some taper to them, for best production method, use a shim under the small end of your log to compensate for the taper. The shim should be half the thickness of the difference in diameter of the two ends of your log. (Example: Log is 12" on small end and 15" on the big end, use a shim of 1 1/2" thick under the small end of the log) You will do that for the first two face cuts on the log.

The short squaring pins welded in the track can be used once you have a good square corner on your cant. When using the short squaring pins you do not have to have the long squaring pins up on the cant, just use the movable dog and pinch it to the short squaring pins to cut down to the last inch. (see Fig F-3 this page)

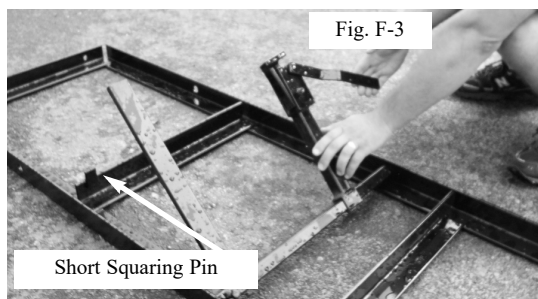

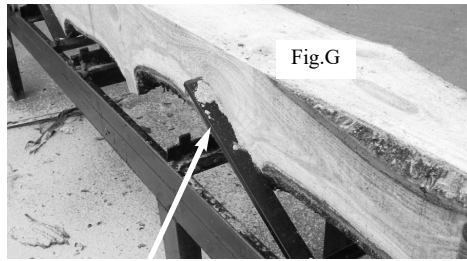

Flat side must be flush and Flat against the squaring pins to assure a square cant.



Adjustable dog, set at an angle so that log can be sawed without interference.

H. Cutting Dimensional Lumber

You can cut down to a 1" thick bottom board. To achieve this you will use the moveable side of the dog and the short squaring pins welded in the track.

- 1 - You will need to determine the size lumber that can be cut and how many, then using the scale start sawing your lumber. Lower the blade to desired thickness and saw your board. Repeat this process until all lumber is cut.
- 2 - You may need to turn your cant to make the desired lumber width.

I. End of Processing Lumber

- 1 - Completely decrease engine throttle and turn engine switch to off position, or if equipped with fuel shut off, turn that to the off position.
- 2 - The blade will continue to turn and will coast to a stop.
- 3 - If you are done sawing for the day, de-tension the blade, so that you do not cause flat spots on the band wheel. Lower the mill head so that the lift cable has a little slack.

J. Replacing the Blade

No matter how well you care for your blade, they will dull after time and need to be replaced. Longevity of your blade depends on how well you maintain it, including cleaning the dirt off of the log before cutting.

- 1 - The engine needs to be stopped, turned off, this ensures that the engine can not be accidentally turned back on. On engines with manual start, you will need to remove the spark plug wire prior to servicing. On electric motors a lockout/tagout should be used.
- 2 - Loosen and remove nuts so you can remove the outside and center guards on all models.
- 3 - Loosen band blade tensioner nut until adjusting bolt nut is flush with threaded end of the bolt.
- 4 - With a gloved hand, put hand on the top of the band blade and push down.
(Use extreme CAUTION, dull blades are still sharp and may be hot).
- 5 - Remove band blade from both band wheels and take out of carriage.
- 6 - Inspect new or sharpened blade, be sure blade teeth are facing in correct direction. Teeth should always point away from the operator. (Towards discharge chute).
Be sure to wipe blade clean of all oily substances prior to installing. A clean, dry rag or cloth works best.
- 7 - Starting from your stationary wheel set the blade on the wheel then thread through your guides. Work the blade over the tensioning wheel until the blade is set.

- 8 - Lightly tension the blade to remove the slack, and then turn the wheel in the direction of travel (towards the operator) 3-4 rotations to be sure the blade is tracking properly on the band wheels.
- 9 - Once the new blade is tracking properly, replace the guards and retension the blade as previously stated.

K. Blade Maintenance

Longevity of band blades depends on how well they are cared for. Using a lube tank, log debarker, band blade sharpener, and tooth setter, all will help keep your blade in top condition. Be sure to clean your logs by using a pressure washer or debarker to keep them free of mud and debris.

L. Blade suggestions

- 1 - Never force a dull blade, this will result in overheating of the blade and result in wavy lumber.
- 2 - Over use of a blade jeopardizes the ability of the saw blade to be re-sharpened.
- 3 - A new blade may stretch after cutting and may have to be re-tensioned to assure quality lumber.
- 4 - Detension the band blade after each day of cutting.
- 5 - Never operate the mill without the guards in place.

The Hud-Son Forest Equipment, Inc. sawmill comes with a band blade and we have an excellent resharpening program for your band blades.

M. Adjusting Sawmill Guides

1 - Purpose of the Guides

- Superior Hud-Son guide design. Supports on the top, bottom and back of the blade, where can the blade go? This guide design limits the chance of blade wander.
- The lower blade guide holds the blade up and decreases the chance of "diving". Most companies only use a top support.
- The closer to the log the guides are, the better support the blade has as it cuts.

2 - Adjusting the guides

- Tools that will be needed:
 - 1) 3/4" wrench
 - 2) 3/4" socket
 - 3) 9/16" wrench
 - 4) 3/16" Allen wrench

NOTICE: If the blade is in contact with the guide bearing during the full cut or most of the cut, you may be pushing too fast or the blade is dull. slow down or change the blade.

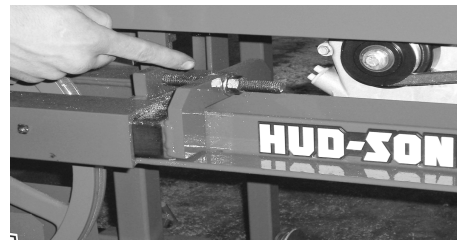

Pictured above is a close-up of the guide. It shows all the bolts and bearings that can possibly be adjusted. Note how the teeth are outside of the guide.

Cutting Logs

You can cut down to a 1" thick bottom board. To achieve this you will use the moveable side of the dog and the short squaring pins welded in the track.

a) You will need to determine the size lumber that can be cut and how many, then using the scale start sawing your lumber. Lower the blade to desired thickness and saw your board. Repeat this process until all lumber is cut.

b) You may need to turn your cant to make the desired lumber.

c) See pictures 1-5.



#1. Place log on track.

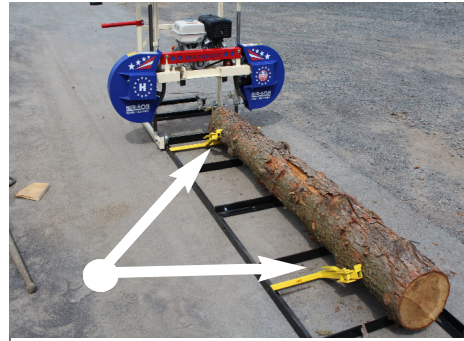

#2. Use log dogs to hold in place.



#3. Adjust blade height, rev engine.



#4. Start cutting.



#5. Cut log into desired dimensional lumber.

COMPONENT PARTS AND IDENTIFICATION REFERENCE FOR PATRIOT

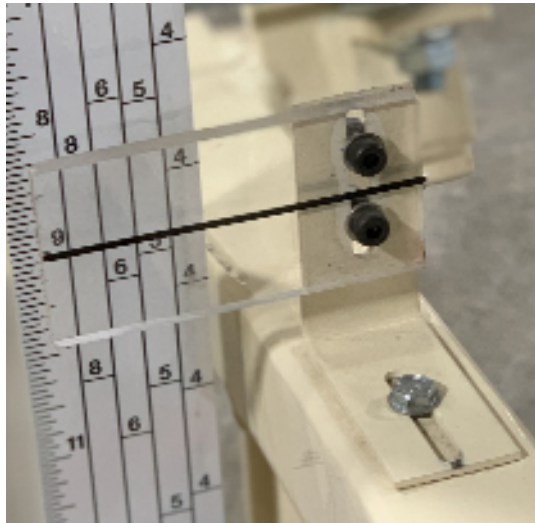

Sight glass and sawmill scale bar



Engine oil drain hole in the motor mount plate.

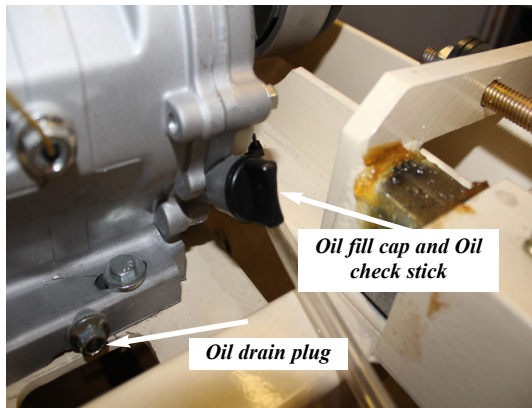

Engine oil check stick and engine oil fill port



Air filter - check or clean daily.

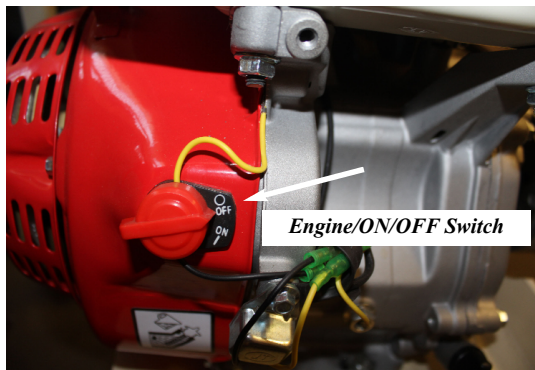

Engine/on/off and start switch



Throttle handle

COMPONENT PARTS AND IDENTIFICATION REFERENCE FOR PATRIOT

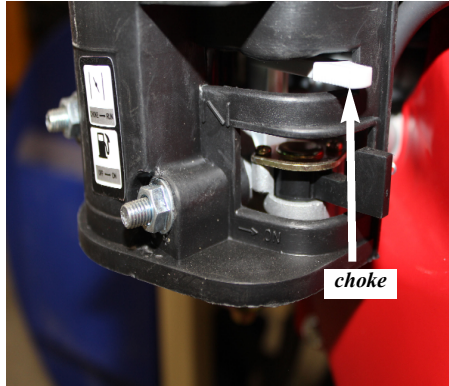

Engine choke on front engine



Fuel tank - non ethanol gasoline only.

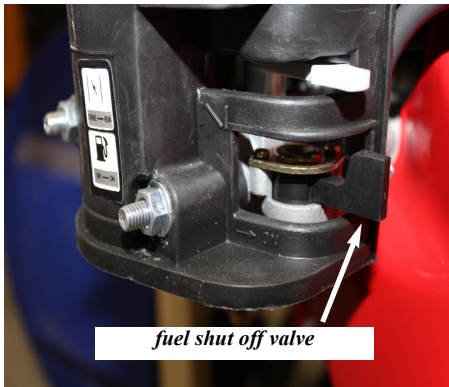

*Fuel shut off valve;
turn fuel off when not in use*



Blade lube tank, keep adding during use and be sure to drain in cold weather.

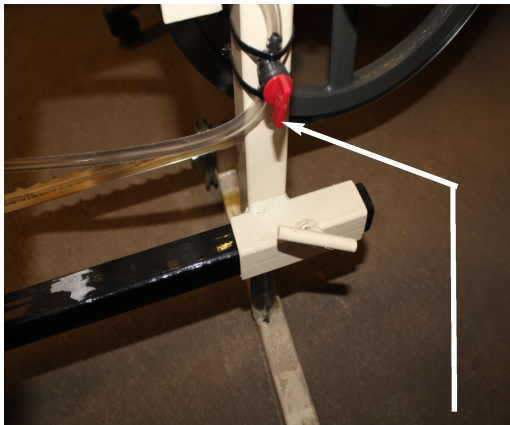

Blade lube flow valve on/off adjustable flow



Push bar handle

COMPONENT PARTS AND IDENTIFICATION REFERENCE FOR PATRIOT

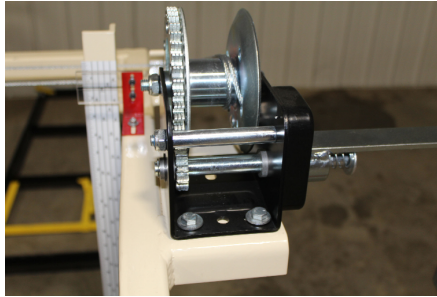

Use a light grease for winch sprocket.

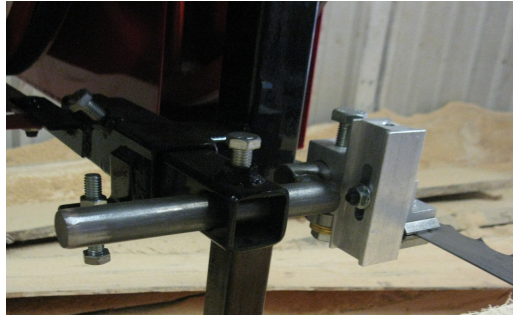

Fixed blade guide



*Adjustable blade guide bar and
T handle locking bolt.*



*Pillow block bearings.
Grease every 80 hours of use*

*(Note: as you cut slabs,
boards, or squares you
may need to adjust the
guide to ensure the best
performance and quality
cuts)*

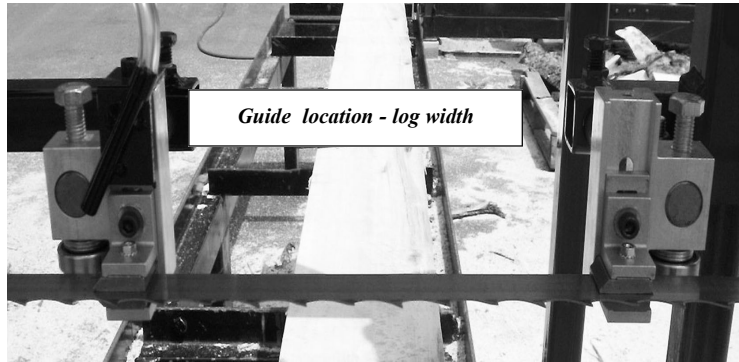

Guide location - log width

*Grease the Blade Tension
thrust bearing between
the (2) cupped washers .*

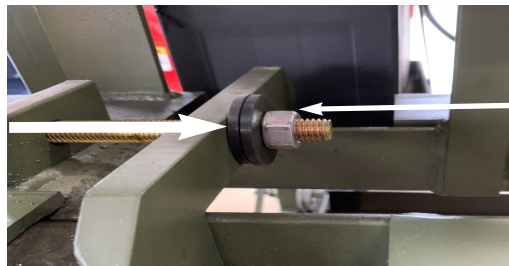

Blade Tension Nut

Keep threads clean and lubed. Blade tension bolt 30-35 ft lbs. torque.

COMPONENT PARTS AND IDENTIFICATION REFERENCE FOR PATRIOT



Tension wheel slide plates. Grease as needed both sides of head.

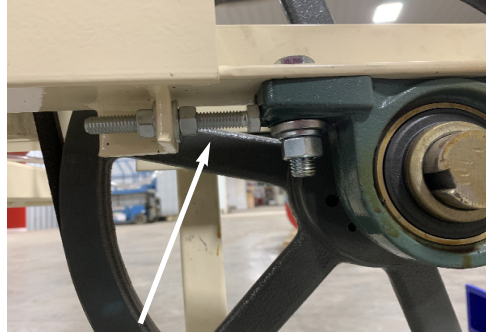

Pillow Block adjusting bolt

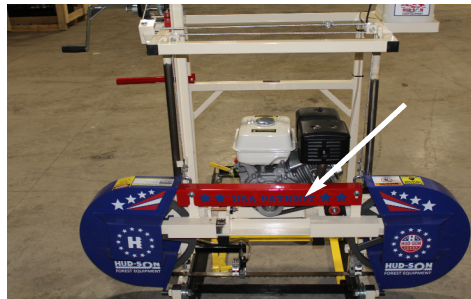

Top blade guard - remove for blade changing



Guard nuts to remove blade guards

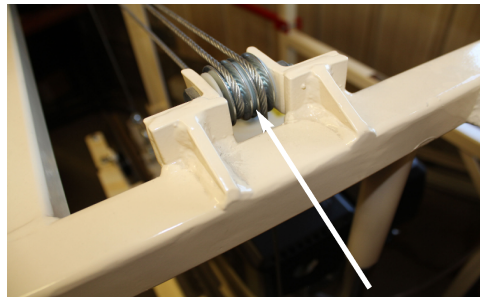

Cable pulleys use a light oil to lube

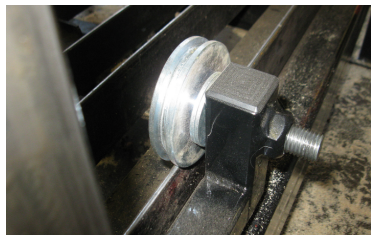
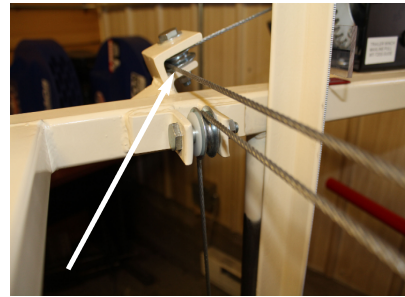

*Track Wheel
Keep track wheels clean when sawing*

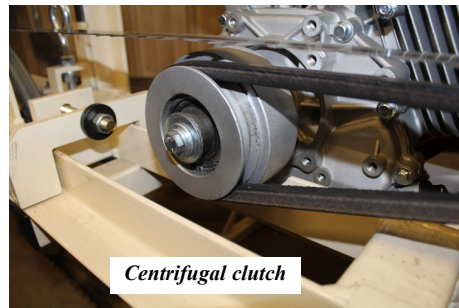

Centrifugal clutch

Blade Guide Care and Maintenance

- All guides are aligned and set at the factory, but occasionally they get moved out of adjustment in shipping or after a period of usage. It is important that they be checked often for proper alignment and adjusted correctly.
 - To adjust your guides correctly you must first tension the blade properly as previously described. A tensioned blade should come off the bottom of the band wheel and run straight across to the other, so there is NO sag between the two wheels.
- 3 - Now that the blade is tight, slightly loosen the Allen head that holds the guide shoes, so that they slide up and down freely. Now loosen the bolt that fastens the aluminum guide bracket to the guide rod, so that the guide bracket can be moved in, out and it can be rotated in either direction.
 - 4 - Set the guide bracket so that the back bearing is on the same plane as the blade, so that if the blade were to wander back it would hit the back bearing evenly across the middle of the roller. If the bearing needs to be adjusted up or down, loosen the bolt that holds it to the guide bracket and space it in either direction using the washers that are on either side of the bearings.
 - 5 - Once the bearing is set, position the guide bracket so that the bearing is 1/8" behind the back of the blade. Once the bearing is in position, tighten the bolt on top of the guide bracket in to place. Be sure the guide is 90° to the blade.
 - 6 - The guide shoes are to be set using a sheet of paper to gauge the spacing. Place the paper between the shoe and the blade, slide the shoe so that it is pinching the paper and tighten the bolt so that the shoe is set in place. Do the same on the bottom of the blade. Note that you do not want the shoe to be pinching the blade so hard that it is prohibiting blade travel
 7. Make sure that all nuts and bolts are tightened firmly.

NOTE:

Hud-Son Saw Mills require a certain amount of care and maintenance, so that it may continue to perform at its best. If you are not confident in your ability to perform the maintenance that is required, please look into having a professional come in and perform the work for you.

N. Using the Lumber Scale

- 1 - All Hud-Son sawmills are equipped with a Lumber Scale. The scale is used to make the dimensioning process simple. The scale incorporates 4 separate scales with the blade kerf factored in for each increment.

Scale	Resulting Thickness
4/4	1"
5/4	1 - 1/4"
6/4	1 - 1/2"
8/4	2"

Note:

The 1" standard ruler does NOT account for kerf. When using this scale be sure to plan on kerf. 1" increments will result in approximately a 7/8" end result, depending on what blade is being used. (See Fig. H on page 16)

Fig. H

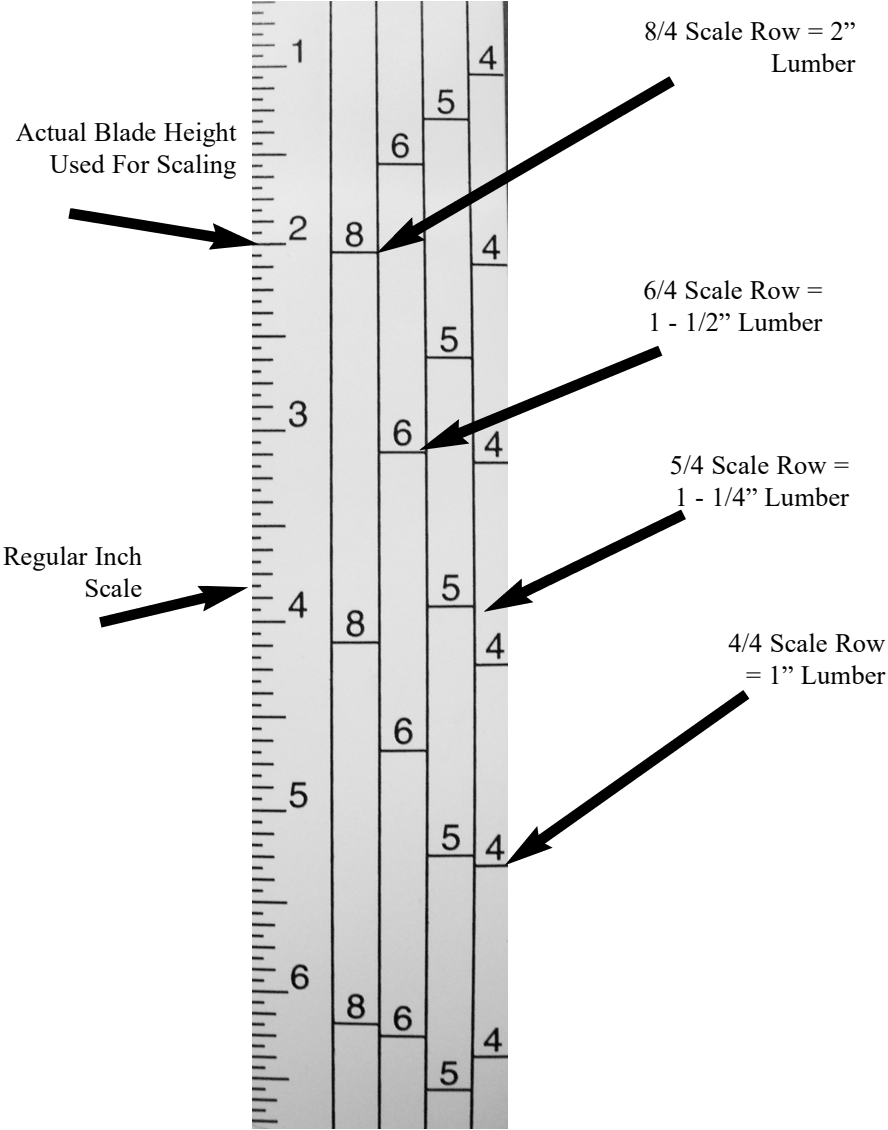

PREVENTATIVE MAINTENANCE CHECK LIST
For Hud-Son Sawmills

Cleaning your Saw Mill

- ✓ Using an air hose, blow off all loose debris that builds around the unit.
- ✓ Use extreme caution when cleaning the mechanism.
- ✓ Never use flammable or combustible materials to clean the mill.
- ✓ Be in a well ventilated area. Always wear protective equipment to prevent injury.
- ✓ Use proper procedure to dispose of waste materials.
- ✓ Wipe down the idler pulley and band wheels using a brush or rag.
- ✓ Clean and inspect blade guides.

Preventative Maintenance

- ✓ For electrical or gasoline motors follow the correct Lockout/Tagout procedures.
- ✓ Check for correct blade tension insuring that there is 30-35 pounds of torque on tensioning bolt/nut.
Check track to make sure it has not moved and check it for level.
- ✓ Check blade tracking, a 1 - 1/4" blade should be centered on band wheels and back of blade should be flush with bandwheel.
- ✓ Check bearings, idler pulley, band wheel belts for wear. Signs of wear are:
 - Excessive heat
 - Squeaking sounds
 - Looseness
- ✓ Grease idler, pulley wheels and bearings.
- ✓ Grease blade tensioner thrust bearing.
- ✓ Grease the lift tubes.
- ✓ Check all belts for wear and to make sure the belt tension is "taut".
Belt should have no more than 1/2" deflection.

Trouble Shooting

<i>Problem</i>	<i>Cause</i>	<i>Solution</i>
<i>Blade is Diving/ Rising</i>	Dull Blade • RPM's Not High Enough • Blade Not Tensioned Properly • Sawing Soft Pitch Wood • (Pitch Build-Up in Blade Gullets)	Sharpen or Replace Blade • Saw at Full Throttle • Check Torque on Tensioning Bolt • (Perform "Flutter" Test) • Use Lubricant on Blade PETROLEUM PRODUCTS, MINERAL OIL OR VEGETABLE OIL SHOULD NOT BE USED ON OUR MILLS - Saw Tree from the Top to the Bottom (small end to wide end) Slow Down • Reset Teeth to Proper Set
<i>Mill Sawing Hard</i>	RPM's Not High Enough on Engine • Belt is Slipping • Sawing Hardwood Dull Blade • Bark or Sawdust Build-up on Wheels or Track	Always Saw at Full Throttle • Adjust Belt Tension Slow Down your Sawing Speed • Sharpen or Replace Blade • Clean Wheels and Track
<i>Clutch Slipping</i>	Dull Blades • Debris and/or Oil can cause slippage • Pushing the saw too fast through log	Sharpen or Replace • Clean out clutch bell Inspect/repair springs and shoes • Slow down
<i>Engine Powers Down Losing RPM's</i>	Pushing the Mill too Fast • Dirty Air Filter Dull Blade	Slow Down your Sawing Speed • Clean/Change Sharpen/Replace Blade
<i>Mill not Sawing Square</i>	Over Dogged • Track Not Level & Square • Cables are Out of Line • Guides are Out of Adjustment • Not Putting Flatside of Cant Flush with Squaring Post on the First Turn • Bad Trolley Bearing	Loosen Dog Pressure • Level Track • Re-adjust Cables • Re-Adjust Blade Guides Put Cant on Flatside, Flush with Squaring Post • Replace Trolley Wheel
<i>Log Moves When Dogged</i>	Over Dogged, too Much Pressure on Dogs	Loosen Dog Pressure
<i>New Blade Will Not Cut</i>	Blade Could Be Turned Inside Out	Turn the Blade So That the Teeth are Pointing to the Discharge Direction
<i>Boards have Fine or Large Lines in them Every Several Inches in a Repeating Pattern</i>	A Tooth in the Blade is Out of Set	Reset Tooth in Blade
<i>New Blade Will Only cut a short dis- tance in Log</i>	Dull Blade • Debris and/or Rocks or Dirt imbedded in the bark • Pushing the saw too fast through log. Nails or Hardware in the log not seen under the bark.	You will need to Debark your logs if they are dirty or muddy ,even clean looking logs have dirt in the bark. Get a Debarking Tool or clean the log with an AX or pressure wash with water. Hardware look for Nails ,staples, fencing,insulators , etc, protruding from the log , cut out or cut off log. Slow Down your Sawing Speed and watch for rocks and dirt in the bark and remove it. • Clean/Change Sharpen/Replace Blade

MAINTENANCE SCHEDULE CHART

Service Recommendations for Hud-Son Sawmills

Service Item	Daily	40 Hours	See Manual
Check Engine Oil Level	✓		
Check/Clean Engine Air Filter	✓		✓
Check Hydraulic Oil Level (fill 1" from top) if applicable	✓		
Clean Unit of Bark, Saw Dust, and other Debris	✓		
Lubricate Grease Fittings and Oil Points (see Diagram for locations)		✓	
Check Tire Pressure - Upon transport (if applicable)		✓	
Check Cylinders and Seals for Leakage (if applicable)	✓		
Check Feed Chains for tension (if applicable)	✓		
Clean Battery Connections (if applicable)		✓	
Check Wiring and Connections for Corrosion and Decay (if applicable)		✓	
Lubricate Chains (if applicable)		✓	
Check Blade Sharpness [always]	✓		
Fuel - fill as needed [unleaded gasoline only]	✓		
Blade Lubricant - fill as needed - Refer to 2A on page 9	✓		
Check hoses/gauges for damage, cracks, leakage (chaffing, dry rot, cracks, replace hoses if applicable)	✓		

FOR BLADE LUBE USE: Summer months use tap water and to prevent pitch build up on the blade, add 1 oz. of dish soap or pinesol to 1 gallon of tap water. This will help keep the blade clean and cooler.

Winter months use regular windshield washer fluid (use - 20 type)

* Change engine oil after 8 hours of operation on a new engine (break -in period)

CAUTION!

Maintenance procedures requiring special training or tools should be performed by a trained technician.

A routine inspection of the entire machine is encouraged. Check to see if all fittings are tight and secure. Make sure all nuts are tightened. Check to see any damage that may need to be repaired before any further damage occurs. Routinely checking the equipment and proper maintenance will help in keeping your Hud-Son WarriorSaw Mill running to the best of its ability.

HUD-SON FOREST EQUIPMENT WARRANTY

Warranty registration must be completed at your dealership or online at www.hud-son.com/warranty within 30 days of purchase.



3 YEAR CONSUMER HOME OWNER
1 YEAR COMMERCIAL USE

Hud-Son Manufactured Products are warranted to be free of manufacture defects in materials and workmanship under normal use and service for a period of time from the purchase date of invoice.

Warranty is limited to the repair of the product and/or parts needed or replaced.

HUD-SON FOREST EQUIPMENT WARRANTY DOES NOT COVER THE FOLLOWING CONDITIONS:

A - Down time or loss of funds, money, and income during repair time.

B - Machines or parts lost or damaged during shipments or handling/shipping companies. Warranty does not cover shipping costs or next day air costs.

C - Normal service wear items such as, but not limited to: V-belts, air filters, fuel filter, oil filters, blades, cutting item, any item that requires servicing.

D - Modifications, alterations, tampering repairs done elsewhere other than by an authorized Hud-Son Forest Equipment Dealership.

E - Products manufactured by other manufacturing companies, such as, but not limited to: Engine and Hydraulic Components.

F - Customer is responsible to return defected parts to the Dealer or HFE at their expense. (If requested)

G - Warranty registration is required to process claims. If warranty registration is not on file a copy of the original invoice may be required before processing claims.

Components used on Hud-Son Forest Equipment products that are manufactured by other manufacturers such as, but not limited to engines, pumps, valves, and hydraulic components, applies to that Manufacturer's Warranty Policy.

Parts and Warranty

Mill Replacement Parts

Out sourced components will be warranted by the respective company for a period equal to the warranty in place at the time of shipping, as shown below from date of purchase.

Description	Part Number	Warranty
Gasoline Engine	13hp Hud-Son	2 Years - call your servicing Dealer.
Electric Motor	[NA]	1 Years - call your servicing Hud-Son Dealer.
1.5" Pillow Block Bearing,	BEA-01-24	6 Years - call your servicing Hud-Son Dealer.
Drive Belt	B79	1 Year - call your servicing Hud-Son Dealer.
Rubber Wheel Belting	BEL-02-58-049	1 Year - call your servicing Hud-Son Dealer.
Urethane Wheel Belting	BEL-04-58-049	1 Year Defect - Not Melted
Tapper Lock, SK Bushing	BUS-01-24-44	1 Year
Drive Belt Tensioner (Idler Pulley)	FX02235B0002	1 Year
Guide Assembly, Left/Right (see breakdown for parts list)	BLG-02-01	30 Days Call your servicing Hud-Son Dealer.
Scale Sticker	DEC-36-01	1 Year
Site Glass Assembly	KUG-100	1 Year
Cable Lift Kit Assembly	CAB-01-0532A	1 Year
Band Blade	WM 132	Call your local dealer 1-800-765-SAWS
1 -1/2" Shaft	SHA-01-8.5	6 Years - Call your servicing Hud-Son Dealer

Description	Part Number	Warranty
Bolt for Track Wheel	HAR-12-12-64	2 Years - call your servicing Hud-Son Dealer.
Track Sections	TE-28	1 Year - call your servicing Hud-Son Dealer.
Axles (Trailer Models)	NA	NA.
Sprockets & Chain	NA	NA
Winch	WIN-01-2000,	1 Years - call your servicing Hud-Son Dealer.
Clutch	HS1004	30 days - call your servicing Hud-Son Dealer.
Band Wheel	WHE-02-44-256	1 Year - call your servicing Hud-Son Dealer.
Log Dog Only	MIL-15-02S	2 Years - call your servicing Hud-Son Dealer.
Track Wheel w/Replacement Bearing	WHE-40-12-53	2 Years - call your servicing Hud-Son Dealer.
Replacement Bearing for Track Wheel	BEA-03-12-24T	2 Years - call your servicing Hud-Son Dealer.
Pulley for Lift Cable	976-004	1 Year - call your servicing Hud-Son Dealer.
Guide Pins	MIL-10-0000-001	2 Years - call your servicing Hud-Son Dealer.
Modular Guide Tube	TUB-20-20,	2 Years - call your servicing Hud-Son Dealer.
Replacement Lube Tank	TAN-02-2.5	2 Years - call your servicing Hud-Son Dealer.

Parts and Warranty

Warranty:

Warranty registration cards must be completed and returned to Hud-Son Forest Equipment, Inc. within 30 days of purchase.

FAILURE TO DO SO WILL VOID THE WARRANTY!!

Warranty claims must be registered with the Dealer/Distributor, and defective parts must be returned to the Dealer/Distributor at the owner's expense. The Dealer/Distributor will assume cost of the shipping one way in regards to any warranty claim. Freight is standard UPS ground. Any expedited services are at an additional charge and will be paid in at the owner's expense before shipping. The shipping of warranty/parts out of the continental USA, will not be covered under warranty. The labor charge out of the continental USA is also not covered under warranty. All mills have a 3 year warranty against manufactures defects.

Warranty Claim Procedure

All warranty claims that are done in the field will be handled as follows:

- 1 - Customer must call the DEALER or DISTRIBUTOR and acknowledge the problem.
- 2 - If the problem can be solved in the field, new parts will be shipped, invoiced and paid for. A credit will be given once the old parts are returned, if covered by warranty.
- 3 - If requested, parts to be replaced must be returned, at owner's expense within 30-days to receive credit.
- 4 - If the problem is deemed too severe to be fixed in the field by the customer, then the customer must return the saw mill, at the owner's expense, to the closest Hud-Son Dealer/Distributor for repair. If the Dealer/Distributor is not qualified to make the repairs, then the equipment must be returned to Hud-Son Forest Equipment, Inc at the Dealer/Distributor expense.
- 5 - If the problem is deemed not to be a warranty problem, an invoice will follow for the parts that were replaced, as well as an invoice for any time spent on the mill by Hud-Son Forest Equipment, Inc staff and/or Dealer/Distributor staff.
- 6 - Any modification to the band mill that is performed by any personnel other than Hud-Son Forest Equipment, Inc direct staff voids the warranty.
- 7 - Any parts that are replaced without the discretion of the Dealer/Distributor voids the warranty on the part the customer is replacing and no reimbursement will be made.
- 8 - Parts purchased by the customer from an outside source, without prior approval from Hud-Son Forest Equipment, Inc will NOT be reimbursed.

Blade Guide

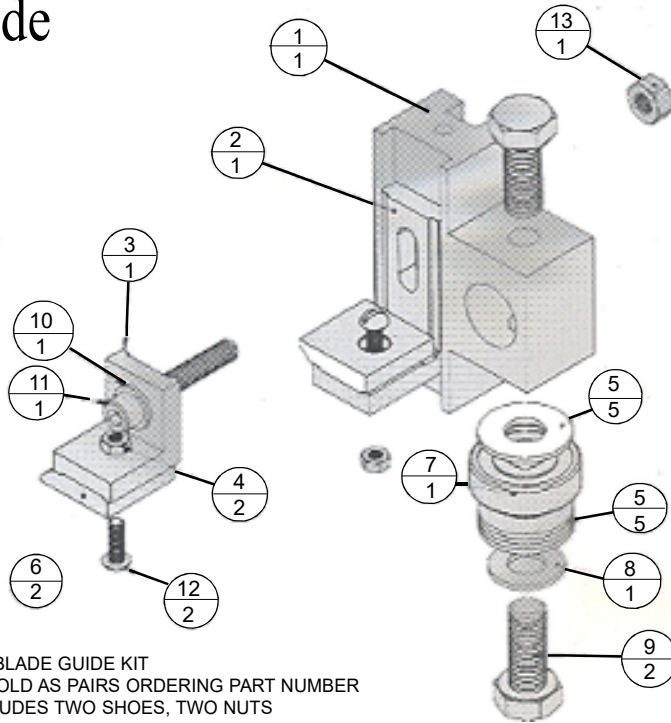

BLADE GUIDE KIT
 NOTE: ITEM 4 IS ONLY SOLD AS PAIRS ORDERING PART NUMBER
 CP20-10A INCLUDES TWO SHOES, TWO NUTS
 (ITEM 13, AND TWO SCREWS (ITEM 12))

Item No	Part No	Description	Qty.
1	BLG-01-06	S Guide Body	1
2	BLG-01-05	Long Shoe Holder	1
3	BLG-01-04	Short Shoe Holder	1
4	F-59351	#8-32 Fine Nut	2
5	HAR-50-06-1000-82	3/8 flat washer USS larger, zinc finish	5
6	BLG-01-01	Guide Shoe (sold as pairs)	2
7	BEA-03-06-16	6200-2RS Bearing	1
8	HAR-50-06-822-68	3/8" flat washer, SAE small	1
9	HAR-03-M10-24	Hex cap screw, M10 x 1.5 x 25 -- 25S	2
10	HAR-50-04-631-70	1/4" Zink SHE Flat Washer	1
11	HAR-03-08-24	1/4-20x1-1/2 Socket Head	1
12	HAR-79-#8-08	Slotted RDHD Screw #8-32x 1/2"	2
13	HAR-29-04	1/4" Course Thread Zinc Finish Nyloc Nut	1

ALWAYS CALL YOUR SERVICING DEALER FIRST!!

Dealers/Distributors carry parts and are very knowledgeable with the inner workings of your sawmill. Remember that modifying your mill or using parts that are Not Hud-Son Forest Equipment Inc approved, can void your warranty.

CE Approved Models: European Mills

All mills outside of the USA parts only.

Warranty on Parts ONLY!! No warranty on labor or shipping.

Warranty/Service Information:

Please contact your local dealer with any issues or to reorder parts.

IF NOT IN THE CONTINENTAL USA - HUD-SON DOES NOT PAY FREIGHT,
CUSTOMS BROKERAGE OR CUSTOMS FEES
OR SHIPPING ON WARRANTY OR LABOR.

Site Glass Assembly

SITE GLASS PART NUMBER UG-100

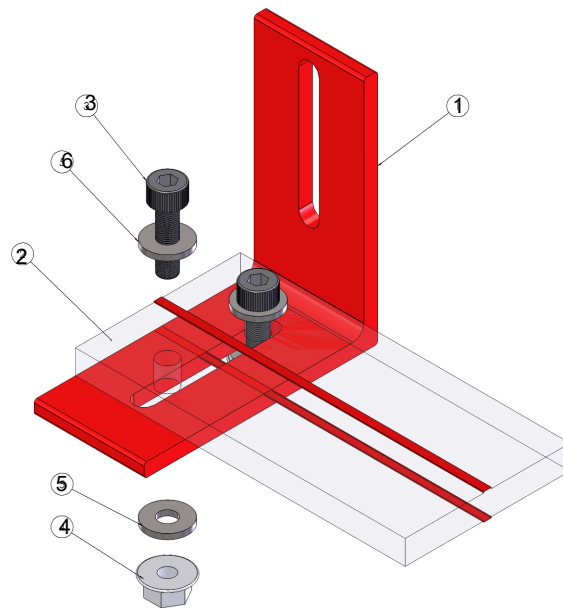

Track Wheel Assembly Parts List

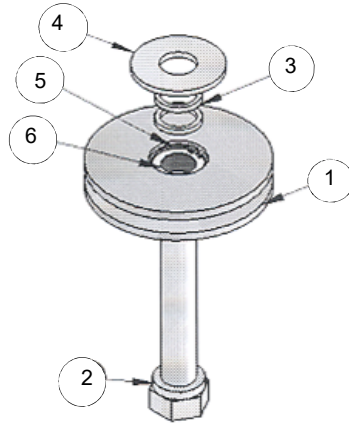

Item No.	Part No.	Description	Qty.
1	WHE-04-12-53	TRACK WHEEL	1
2	HAR-12-12-64	SHOULDER BOLT	1
3	HAR-55-12-1000-125	3/4"X1"X1/8" ZNFW	2
4	HAR-50-12-2000-063	3/4" ZFW FLAT WASHER	1
5	LW-0579	C-CLIP OR SNAP RING	1
6	BEA-03-12-24T	3/4" BEARING	1

Sheave Assembly Parts List w/Belting for Patriot sawmill

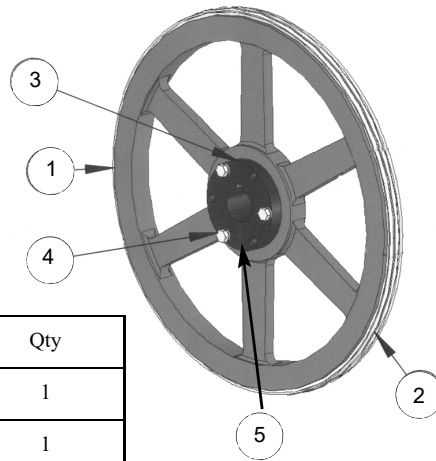

Item No	Part No	Description	Qty
1	WHE-02-44-256	16" SHEAVE	1
2	BEL-04-58-049	Belting Crown Top	1
3	BUS-01-24-44	Q-BUSHING	1
4	HAR-01-05-32	Bolt	3
5	Keystick	1/2" Keystick	1

Clutch for Patriot Sawmill

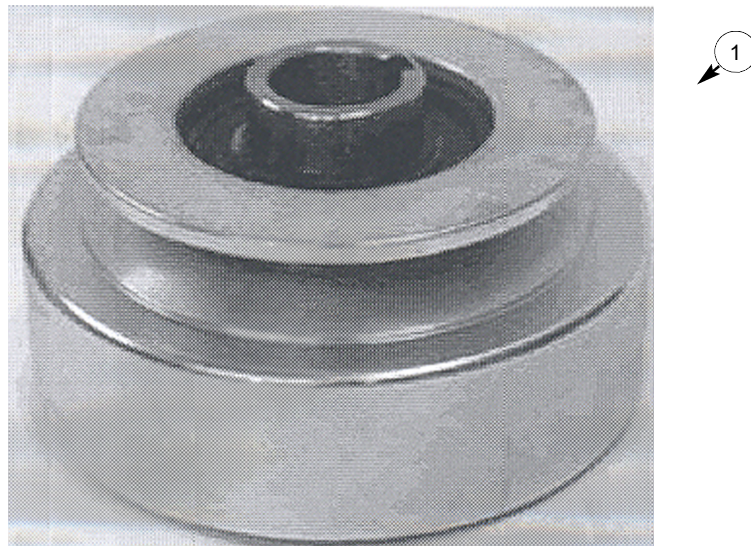

Item No	Part No	Description	Qty
1	HS 1004	CLUTCH	1

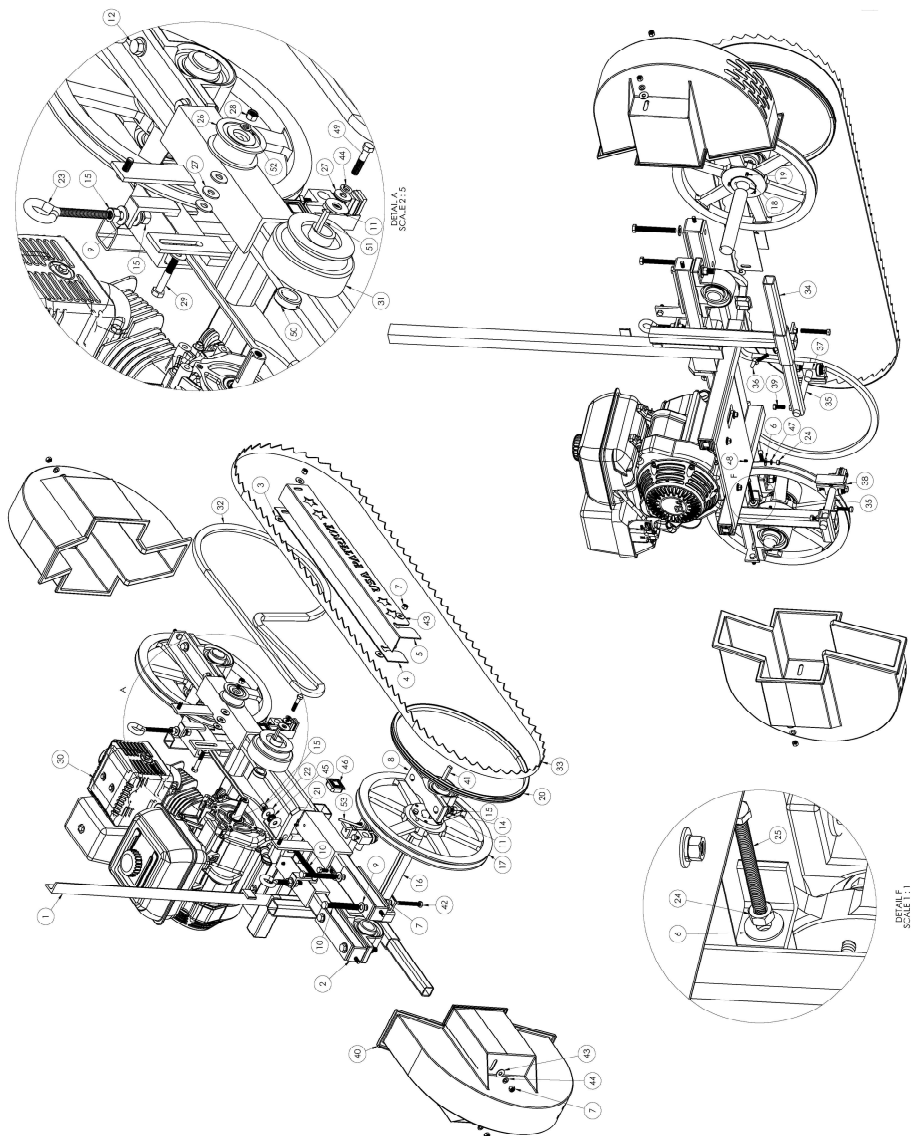

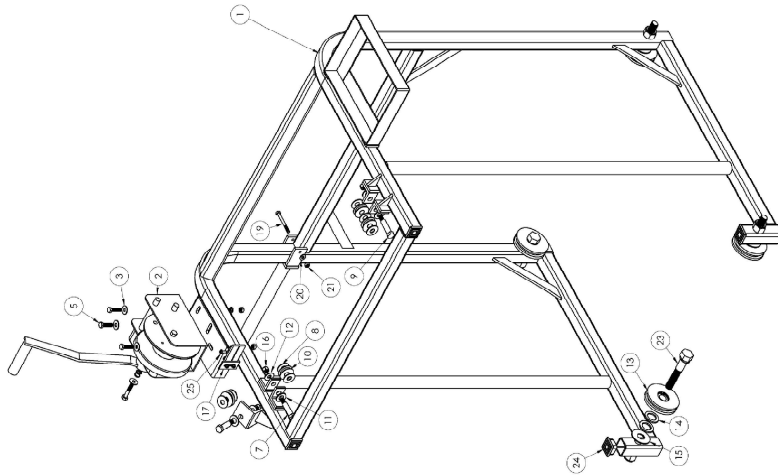
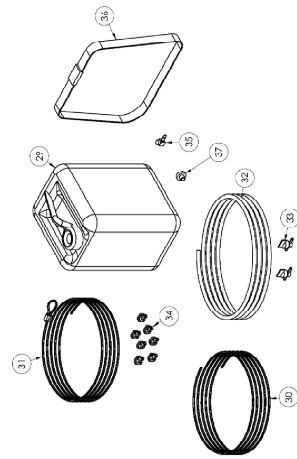
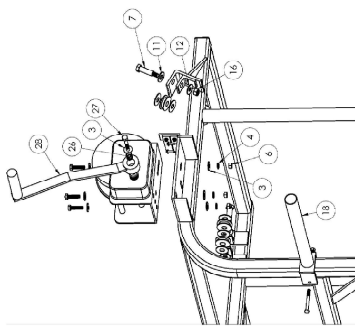



Thank you for choosing



Hud-Son Forest Equipment, Inc.
8201 State Rt. 12, PO Box 345 Barneveld, NY 13304
info@hud-son.com

For more information please contact your local Dealer

WWW.HUD-SON.COM

