



WWW.HUD-SON.COM • 800.765.SAWS



OSCAR-52 SAWMILL OPERATOR'S MANUAL

8201 STATE ROUTE 12 • PO BOX 345 • BARNEVELD, NY 13304

A N O T E F R O M H U D - S O N

Thank you for your purchase of a sawmill from Hud-Son Forest Equipment. We are pleased that you chose us as your supplier of your forestry equipment.

Hud-Son Forest Equipment has been in the forestry business since 1965 and prides itself on developing new and innovative products for the forestry business.

Our product line is always transforming so please check us out on the web at www.hud-son.com for the up and coming developments we are making.

Should you have any questions with the setup of your mill or have any technical questions please feel free to contact our onsite technician Monday - Friday, 8 to 4:30 and Saturdays from 8 to noon eastern time at 800-765-7297. We are always available to our customers for any questions or concerns they may have about their equipment. You can also contact the dealer you purchased your equipment from.

C O N T E N T S

- 2A note from Hud-Son
- 3Introduction
- 4Safety
- 7Set Up
- 7Set Up Track Assembly
- 17Care & Maintenance
- 19Parts & Warranty
- 21-23 Drawings & Parts List

INTRODUCTION - Purchaser Agreement

By accepting the delivery of your sawmill by Hud-Son Forest Equipment you agree that you will not modify your mill from it's original assembly. This will VOID any warranty from Hud-Son Forest Equipment.

Please fill out the information for quick reference:

Dealer: _____
Phone Number: _____
Address: _____
Purchase Date: _____
Model: _____
Serial Number: _____

Safety Guidelines

The reason for the safety section is to inform the operators and maintenance personnel, the precautions that should be taken while operating or servicing the Hud-Son Mills. Please use good judgement and keep safety in mind when operating Hud-Son machinery. Please read and follow ALL the instructions in this manual before operating the Hud-Son Mill safely at all times. These instructions were produced for your benefit. Your ability to understand and follow the instructions is essential for the safe operation of this product. Always call your servicing dealer if you are in doubt before operation of any kind.

General Safety Procedures

1 - Always wear safety glasses, ear protection, and gloves while operating or servicing the



2 - Keep all body parts and foreign objects away from all moving parts. Do not reach into the machine while it is still operating. (Be Sure The Machine Is **OFF**.)

3 - Do not attempt to override any safety features on the machine.

4 - Inspect the machine before every use for wear, damage, and that it's functioning correctly. If the machine has been damaged or is not running correctly, **DO NOT** attempt to operate the machine. Repair or replace all parts when necessary.

5 - Do not wear loose clothing or jewelry while operating or servicing the machine.

6 - All replacement parts should be of the same specifications as the original parts on your Hud-Son machine.

7 - **All guards and covers must be in place before operating the machine.**

8 - Before starting the machine be sure that it is set up properly.

9 - **DO NOT** operate or service any machinery while under the influence of drugs or alcohol, while tired or if you are unable to control your movements.

10 - All worn or damaged decals should be replaced.

11 - Any modifications to the machine requires written approval from Hud-Son Forest Equipment.

12 - The sawmill should only be used when it is on level stable ground.

The safety rules are made for the benefit of the persons operating and servicing the machine, to prevent injury to oneself or others. Please review all setup and operating procedures before attempting to run the machine, whether covered in this manual or not, to ensure the safest operation of this product.

Hud-Son Forest Equipment is not liable for damage to property or personal injury due to the failure of any person and/or operator to follow the instructions and recommendations set forth in this manual or any other instructions or recommendations contained in other literature issued by other vendor manuals in the owner's kit.

Product Safety Decals

The decals below are used on the Hud-Son Saw Mills to identify warnings and prohibited actions. It is very important that you understand the meaning of the decals for your safety and the safety of others. Decals are to be replaced if worn or illegible.

CAUTION - Be EXTRA careful around these areas, unsafe practices may cause personal injury or damage.

DANGER - Be careful around any rotating parts, they may cause personal injury or damage.

DANGER - Be sure to be very cautious and alert, these areas may cause personal injury or damage.

CAUTION - Operating equipment without guards may cause personal injury or damage.

BLADE LUBE TANK - Be sure to use the correct lubrication, if incorrect lube is used it may cause personal injury or damage.

NOTICE - Please remember to send in warranty card and information.

CAUTION - All debris need to be removed from machine before transporting, failure to do so may cause personal injury or damage.



Receiving and Unit Inspection

1 - Upon receiving your unit do a walk around and visual inspection of the unit. Make note of any damage and contact us immediately with any issue you may have. Note: All equipment is assembled, tested and inspected before shipping. Damage can occur during transit, which could cause the unit to not operate correctly.

Unpacking Unit

- 1 - Flat bed trailer delivery: remove straps or chains securing the unit.
- 2 - Remove lag screws and strapping that secures the machine to the skid.

Moving the Unit

(Forklift is needed for track units)

- 1 - Machine needs to be lifted at the lift point, see picture for points.
 - a. Use a safety devise for lifting to avoid any damage/injury.
- 2 - Move unit to operator's site, lower unit and remove unit from forks.



Before operating the Hud-Son Saw Mill the following procedures need to be performed:

- 1 - Check oil and fuel levels
- 2 - Check blade lubrication and hydraulic levels (if applicable)
- 2-A** - Check blade lubrication and hydraulic levels.

DO NOT USE: petroleum products, petroleum based products, flammable products, a vegetable oil based product. The above products mixed with water or straight will cause damage to your mill. The fluid will be slippery between the blade and wheel belting causing blade to come off.

DO USE: In the summer months use tap water. If there is a problem with pitch build up on the blade, add 1 oz. of dish soap or pinesol to 1 gallon of tap water. This will help keep the blade clean and less heat.

In the Winter Months water will freeze in the lube tank. Use regular windshield washer fluid (usually blue in color) If there is a pitch build up problem add the 1 oz. of dish soap or pinesol.

Adjustment: Before starting the engine, adjust the flow of lube to the blade by adjusting the flow shut off valve so there is a constant drip. If more lube is necessary, continue to adjust the valve until the desired flow is acquired.

- 3 - Be sure the blade is sharp and tight
- 4 - Be sure all levers and switches are in the neutral/center position before starting the engine (if applicable)
- 5 - Be sure all persons are clear of the equipment
- 6 - Make sure the unit is level and stable.

Start Engine Procedure

- 1 - Summer Use: Be sure to let the unit idle for at least 5 minutes before any use.
- 2 - Winter Use: Be sure to let the unit idle for at least 15 minutes before any use.
- 3 - If the unit has been sitting for a period of time, allow the unit to run long enough to

Steps for Setting-Up the Hud-Son Saw Mill

A. Machine Set-Up (ground track unit)

1. For best results and easier set-up, the mill location should be level and free of obstructions.
2. A level cement pad is the best option, but square timbers also work well. You will need to support the track at each joint and under each cross member.
3. You will need to be sure that the mill is level from front to back and side to side. The better the mill is supported the better the mill work.
4. There should be a 4 ft. clear work area around the entire mill.

B. Welded Track Assembly

1. Dogs needs to facing in the same direction, the moveable dogs need to be on the same side of the track which is on the operator's side of the mill head.
2. There are additional holes in the track so that the dogs can be moved to different positions.
3. The tracks are bolted together using bolt and nuts. The Oscar-52 mills will have 2 bolt/nuts: the Oscar-52 mills will have 3 bolts/nuts. Line up the tracks so that the center holes align. Using the provided bolts put them through the holes and finger tighten the nuts. Adjust the track height so that the 2 pieces of track meet flush and level. Work one side then the other, once level has been achieved, check the track to see if it aligns vertically. If the track is not aligned correctly use a hammer to tap it into position. Once this is accomplished tighten the bolts securely.

Moveable dogs on one side

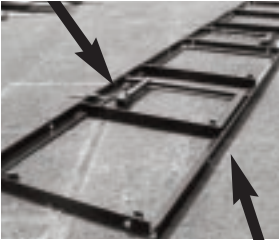

Track on level ground, free of obstructions

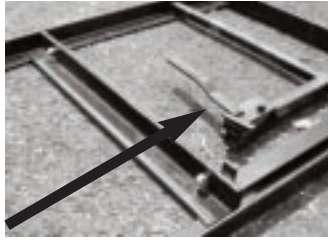

Bolted together Track
Flush & Level

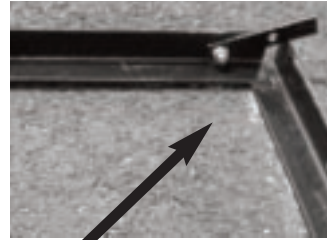

Track Stops

Set-Up and Operation

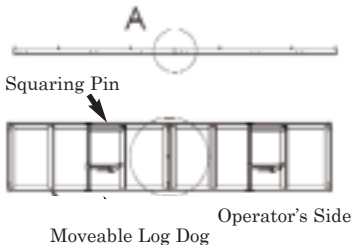

Moveable Log Dog

Operator's Side

Correct Track Set-up

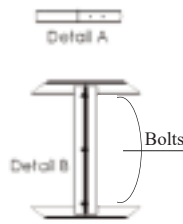

Detail B

Bolts

- 4 - The track comes with four track stop tabs. They consist of the track stop tab bolt and nut. Place the tracks stops in the four end corners of on the inside of the track. Place them on the inside of the track secure them into place with the bolt and nut. The track stop tabs are placed at an angle over the track to prevent any further travel of the mill head.

5. To saw a board accurately, the track needs to be straight and flat. To obtain this, use a string tied tight from end to end or a level. If the track/trailer has a crown or dip, you will not be able to saw a straight board.

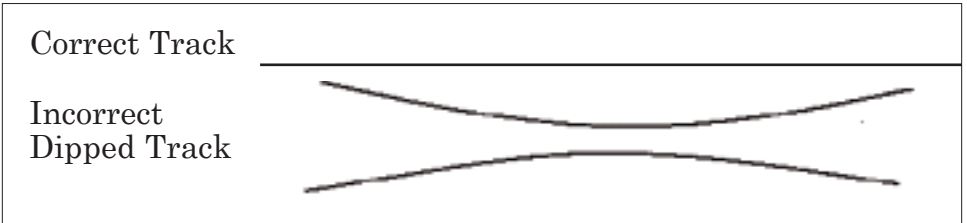

C. Setting Head on Track (If Applicable) Ground Models

Once your track is level, you are ready to set the head on the track. Once again, be sure the area is still free and clear of obstructions. You will want the head to roll freely down the track.

1. Install the head with operator's side on the same side as the moveable dog. The discharge side is the side with the squaring pins.
2. Raise the head 3 inches and roll from one end to the other. The head should roll smoothly along the track. If the head "thumps" when it passes over the track joint, check to make sure the tracks are level. Re-level the track and try rolling the head again. Also be sure to watch the track as you roll the head, if the track moves, you will need to support the track in that area.
3. Set the guide bracket so that the back bearing is on the same plane as the blade, so that if the blade were to wander back it would hit the back bearing evenly across the middle of the roller. If the bearing needs to be adjusted up or down, loosen the bolt that holds it to the guide bracket and space it in either direction using the washers that are on either side of the bearing.
4. Once the bearing is set, position the guide bracket so that the bearing is spaced 1/8" behind the back of the blade. Once the bearing is in the position, tighten the bolt on the top of the guide bracket into place, Be sure the guide is 90 degrees to the blade.

ALWAYS WEAR GLOVES AND EYE PROTECTION WHEN OPERATING SAWMILL.



Correct head placement; Operators side is on side with the scale stick.



Squaring arm on right, adjustable dog on left.



*Pictured is a close-up of the guide
It shows all the bolts and bearings that can possibly be adjusted. Note
how the teeth are outside of the guide.*

Set-Up and Operation

E. Tensioning the Blade on all Models

NEVER tension your blade with the engine running. We ship with slight tension. No tension will make the blade fall off during shipment. If there is tension left on the blade for a period of time, it can cause flat spots in the belt.

This will cause the blade to fall off the wheel. Always remember to de-tension your blade when you are done sawing for the day.

1. To tension or loosen the blade, see figure below.
2. Turn the adjusting bolt or stud, clockwise until 60-70 ft.lbs of torque is achieved. The recommended tool for this is a torque wrench. By hand, rotate blade 3-4 full revolutions; this centers the blade on the wheels.
4. With gloves on, pull up on the blade at the center guard. Allow for no more than a ¼" movement up or down on the blade.
5. Blade guides must not be so tight they cause the blade to heat up. If this occurs re-adjust guides.
6. Perform a simple test call the "Flutter" test. Put the guards on and then run the engine at full RPM's (be sure the blade is not in a cut during this test) and watch the blade under the top blade guard. The blade must run straight, if it does not, shut the engine down and apply more tension. Keep in mind that over tensioning will also cause the blade to flutter. You should have attained proper tension around 60-70 ft.lbs. pounds.
7. A tensioned blade should come off the bottom of the band wheel and run straight across to the other band wheel, so there is NO sag in the blade between the two wheels.
8. After your first cut wit a new blade be sure to check your tension. New blades will get hot and may stretch slightly.

1. To tension the blade,
2. Turn the adjusting bolt or stud, clockwise until 70 ft.lbs of torque is achieved. The recommended tool for this is a torque wrench.



*Tension bolt for
larger units
(Oscar-52)*

F Setting Logs

Once the track is set, the head is in place and the blade is tensioned correctly, you are almost ready to cut.

1. Place the log determined by the mills size, on the center of the track. Using the log dogs secure the log to the track. Be sure to dog the log high enough (1/2" way up the log) to ensure the log does not move.



G. Getting Ready to Cut

Now is the time to debark or clean your log. This can be achieved by the simple chain-saw attachment, called a Log Debarker (available through Hud-Son Forest Equipment Inc.) or you can pressure wash or use whatever method available to remove any mud or bark from the logs. By debarking and cleaning your log it will extend the life of your blade.

1. Adjust the Hud-Son guides so that they are slightly (no more than 2 inches) wider than the maximum width of the log.



(Note: as you cut slabs, boards or squares you may need to adjust the guide to ensure the best performance and quality cuts)

2. Find the top of the log with the blade. You will be removing the top portion of the log. (top slab)
3. Make sure your blade will clear your dog assembly.
4. Start your engine, let it idle for at least 5 minutes. (Refer to the engine manual for proper engine maintenance)
5. With the engine in idle position, increase the throttle to start the blade. Sawing should

always be done with the engine in full throttle

6. Gently push the saw head through the log, pushing on the head frame. If the engine starts to labor, you are going to fast, slow down. Go slow through burls and knots as the engine may bog down through these parts of a log.
7. When you are at the end of the log, power down the engine, crank the head up so that will clear the log and roll back to the front of the log. For ease of operation, put the slabs on the operator's side of the mill, this way you will not have to dig through sawdust for your lumber.
8. You now have a flat surface on top of your log, remove the cheaters (if applicable), you will no longer need them, as long as the log dogs will hold the log in place.
9. Set your log dog assembly so that they are standing in the track. Turn the cut side of the log, using a cant hook, $\frac{1}{4}$ of a turn. The flat side must be flush against the squaring pin to assure a square cant.
10. Adjust the log dog at an angle to the track so that the blade can pass over the top, but so that the dogs are effective in securing the log.
11. Once again, increase the engine throttle to start the blade, and saw another slab. You will repeat step (I) until your log is squared into a cant. You may now saw your dimensional lumber.
12. Steps (I-K) may not be applicable if a cant is not desired.



Place flat side, flush against squaring pin to ensure a square cant.



Adjustable dog, set at an angle so that log can be sawed without interference.

H. Cutting Dimensional Lumber

You can cut down to a 1 1/2" thick bottom board with the Oscar 52. To achieve this you will use the moveable side of the dog and the short squaring pins welded in the track.

1. You will need to determine the size lumber that can be cut and how many, then using the scale start sawing your lumber. Lower the blade to desired thickness and saw your board. Repeat this process until all lumber is cut.
2. You may need to turn your cant to make the desired lumber.

I. Replacing the Blade

No matter how well you care for your blade, they will dull after time and need to be

changed. Longevity of your blade depends on how well you maintain it.

1. The engine needs to be stopped, turned off and the key removed, this ensures that the engine can not be accidentally turned back on. On engines with manual start, you will need to remove the spark plug wire prior to servicing. On electric motors a lockout/tagout should be used.
2. Loosen and remove retainer nuts so you can remove the outside and center guards on all models.
3. Loosen band blade tensioner bolt until adjusting bolt is flush with threaded plate.
4. With a gloved hand, put hand on the top of the band blade and push down. (Use extreme CAUTION, dull blades are still sharp and may be hot).
5. Remove band blade from both band wheels and take out of carriage.
6. Inspect new or sharpened blade, be sure blade teeth are facing in correct direction. Teeth should always point away from the operator. (Towards discharge chute). Be sure to wipe blade clean of all oily substance prior to installing. A clean, dry rag or cloth works best.
7. Starting from your stationary wheel set the blade on the wheel then thread through your guides. Work the blade over the tensioning wheel until the blade is set.
8. Lightly tension the blade to remove the slack, and then turn the wheel in the direction of travel (towards the operator) 3-4 rotations to be sure the blade is tracking properly on the wheel.
9. Once the new blade is tracking properly, replace the guards and re-tension the blade as previously stated.

J. End of Processing Lumber

1. Completely decrease engine throttle and turn engine switch, red one, to off position.
2. The blade will continue to turn automatically and will coast to a stop.
3. If you are done sawing for the day, de-tension the blade, so that you do not have flat spots. Lower the mill head so that the lift cable has slack.

K. Blade Maintenance

Longevity of band blades depends on how well they are cared for. Using a lube tank, Log Debarker, band blade sharpener, tooth setter, all will help keep your blade in top condition. Be sure to clean your logs by using a pressure washer or debarker to keep them free of mud and debris. Refer to 2A on page 6

L. Blade suggestions

1. Never force a dull blade, this will result in overheating of the blade and result in wavy lumber.
2. Overuse of a blade jeopardizes the ability of the saw blade to be re-sharpened.
3. A new blade may stretch after cutting and may have to be re-tensioned to assure quality lumber.
4. De-tension the band blade after each day of cutting.
5. Never operate the mill without the guards in place.

The Hud-Son Forest Equipment, Inc sawmill comes with a band blade and we have an excellent re-sharpening program for your band blade.

M. Adjusting Sawmill Guides

1. Purpose of the Guides

Superior Hud-Son guide design. Supports on the top, bottom and back of the blade, where can the blade go? This guide design limits the chance of blade wander. The lower blade holds the blade up and decreases the chance of "diving". Most companies only use a top support. The closer to the log the guides are the better support the blade has as it cuts.

2. Adjusting the guides

- Tools that will be needed:
 - 9/16" wrench
 - 3/16" Allen wrench
 - 1 3/8 wrench or socket
 - Safety glasses and gloves

All guides are aligned and set at the factory, but occasionally they get moved out of adjustment in shipping or after a period of usage. It is important that they be checked often for proper alignment and adjusted correctly. To adjust your guides correctly you must first tension the blade properly as previously described. A tensioned blade should come off the bottom of the band wheel and run straight across to the other, so there is NO sag between the two wheels.

3. Now that the blade is tight, slightly loosen the Allen head that holds the guide shoes, so that they slide up and down freely. Now loosen the bolt that fastens the aluminum guide bracket to the guide rod, so that the guide bracket can be moved and it can be rotated in either direction.

4. Set the guide bracket so that the back bearing is on the same plane as the blade, so that if the blade were to wander back it would hit the back bearing evenly across the middle of the roller. If the bearing needs to be adjusted up or down, loosen the bolt that holds it to the guide bracket and space it in either direction using the washers that are on either side of the bearings.

5. Once the bearing is set, position the guide bracket so that the bearing is 1/8" behind the back of the blade. Once the bearing is in position, tighten the bolt on top of the guide bracket in to place. Be sure the guide is 90° to the blade.

6. The guide shoes are to be set using a sheet of paper to gauge the spacing. Place the paper between the shoe and the blade, slide the shoe so that it is pinching paper and tighten the bolt so that the shoe is set in place. Do the same on the bottom of the blade.

Note that you do not want the shoe to be pinching the blade so hard that it is prohibiting blade travel

7. Make sure that all nuts and bolts are tightened firmly.

N. Using the Lumber Scale

1. All Hud-Son sawmills are equipped with a Lumber Scale. The scale is used to make the dimensioning process simple. The scale incorporates 4 separate scales with the blade kerf factored in for each increment.

Scale	Resulting Thickness
4/4	1"
5/4	1 - 1/4"
6/4	1 - 1/2"
8/4	2"

Note:

The 1" standard ruler does NOT account for kerf. When using this scale be sure to plan on kerf. 1" increments will result in approximately a 7/8" end result, depending on what blade is being used.

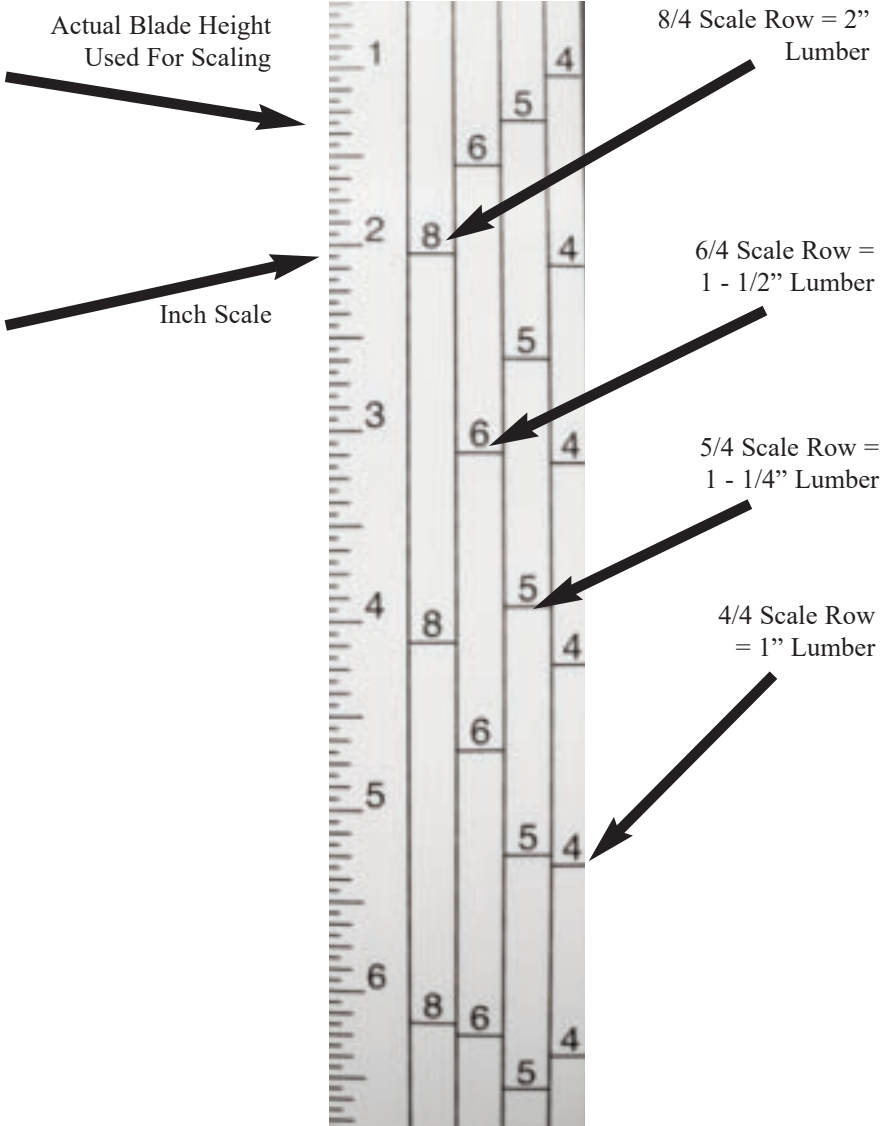

Care and Maintenance

Hud-Son Saw Mills require a certain amount of care and maintenance, so that it may continue to perform at its best. If you are not confident in your ability to perform the maintenance that is required, please look into having a professional come in and perform the work for you.

Cleaning your Saw Mill

- ✓ Using an air hose, blow off all loose debris that builds around the unit.
- ✓ Use extreme caution when cleaning the mechanism.
- ✓ Never use flammable or combustible materials to clean the mill.
- ✓ Be in a well ventilated area. Always wear protective equipment to prevent injury.
- ✓ Use proper procedure to dispose of waste materials.
- ✓ Wipe down the idler and pulley wheels using an air hose, brush or rag.
- ✓ Clean and inspect blade guides.

Preventative Maintenance

- ✓ For electrical engine follow the correct Lockout/Tagout procedures.
- ✓ Check for correct blade tension guaranteeing that 40-45 pounds of torque is on tensioning bolt/nut.
- ✓ Check blade tracking, a 1 - 1/2" blade should be centered on band wheels.
- ✓ Check bearing, idler and pulley wheels for wear. Signs of wear are:
 - ✓ Excessive heat
 - ✓ Squeaking sounds
 - ✓ Looseness
- ✓ Grease idler, pulley wheels and bearings.
- ✓ Grease blade tensioner shaft.
- ✓ Grease the lift tubes.
- ✓ Check all belts for wear and to make sure the belt tension is "taut".
Belt should have no more than 1/2" deflection.

MAINTENANCE SCHEDULE CHART

Service Recommendations for Hud-Son Sawmills

Service Item	<i>Daily</i>	<i>40 Hours</i>	<i>See Manual</i>
Check Engine Oil Level	✓		
Check/Clean Engine Air Filter			✓
Check Hydraulic Oil Level (fill 1" from top) if applicable	✓		
Clean Unit of Bark, Saw Dust, and other Debris	✓		
Lubricate Grease Fittings and Oil Points (see Diagram for locations)		✓	
Check Tire Pressure - Upon transport (if applicable)		✓	
Check Cylinders and Seals for Leakage	✓		
Check Feed Chains for tension (if applicable)	✓		
Clean Battery Connections		✓	
Check Wiring and Connections for Corrosion and Decay		✓	
Lubricate Chains (if applicable)		✓	
Check Blade Sharpness	✓		
Fuel - fill as needed	✓		
Blade Lubricant - fill as needed - Refer to 2A on page 6	✓		
Check hoses/gauges for damage, cracks, leakage (chaffing, dry rot, cracks, replace hoses if applicable)	✓		

*** Change engine oil after 8 hours of operation on a new engine (break -in period)**

CAUTION!

Maintenance Procedures requiring special training or tools should be performed by a trained technician.

A routine inspection of the entire machine is encouraged. Check to see if all fittings are tight and secure. Make sure all nuts are tightened. Check to see any damage that may need to be repaired before further damage occurs. Routinely checking the equipment and proper maintenance will help in keeping the Hud-Son Saw Mill running to the best of its ability.

Parts and Warranty

Mill Replacement Parts

Out sourced components will be warranted by the respective company for a period equal to the warranty in place at the time of shipping, as shown below from date of purchase.

Description	Part Number	Warranty
Gasoline Engine		See Engine Manufacturer's Manual for Warranty
Electric Engine		1 Years - call your servicing Hud-Son Dealer.
1.5" Pillow Block Bearing, 1" Pillow Block Bearing	BEA-01-24	6 Years - call your servicing Hud-Son Dealer.
Drive Belt	BEL-01-24, BEL-02-58-077, BEL-02-58-085, BEL-02-58-092	1 Year - call your servicing Hud-Son Dealer.
Rubber Wheel Belting	BEL-02-58-049, BEL-02-58-56.5	1 Year - call your servicing Hud-Son Dealer.
Urethane Wheel Belting	BEL-04-58-049, BEL-04-58-56.5, BEL-04-58-077	1 Year Defect - Not Melted
Tapper Lock, SK Bushing	BUS-01-24-44	1 Year
Drive Belt Tensioner (Idler Pulley)	WHE-03-06-48-1250	1 Year
Guide Assembly, Left/Right (see breakdown for parts list)	BLG-02-01	30 Days Call your servicing Hud-Son Dealer.
Scale Sticker	DEC-36-01	1 Year
Site Glass Assembly	KIT-001	1 Year
Cable Lift Kit Assembly	CAB-01-0532A	1 Year
Band Blade	BLA-167-20 (BLA-LENGTH-WIDTH IN 16THS)	1-800-765-SAWS
1 -1/2" Shaft	SHA-01-12.5 (SHA-01-LENGTH IN INCHES)	6 Years - Call your servicing Hud-Son Dealer

Lift Tubes	TUB-20-XXX (XXX=LENGTH IN INCHES)	2 Years
Bolt for Track Wheel	HAR-12-12-64	2 Years - call your servicing Hud-Son Dealer.
Track Sections		1 Year - call your servicing Hud-Son Dealer.
Axles (Trailer Models)		1 Year - call your servicing Hud-Son Dealer.
Hydraulic Motors, Pumps, Valves, Hose & Fittings		1 Year - call your servicing Hud-Son Dealer.
Sprockets & Chain		90 Days - Call Hud-Son and ask for the warranty department
Winch	WIN-01-2000, WIN-02-2500 (ELECTRIC)	1 Years - call your servicing Hud-Son Dealer.
Winch Switch	ELE-08-01-E	1 Years - call your servicing Hud-Son Dealer.
Winch Solenoid	ELE-08-02-A	1 Years - call your servicing Hud-Son Dealer.
Clutch	(HFE-121)CLU-02-12 (HFE 30/36, OSCAR MODELS) -CLU-02-16 OSCAR 52/60 CLU-02-18	30 days - call your servicing Hud-Son Dealer.
Band Wheel	WHE-02-44-288	1 Year - call your servicing Hud-Son Dealer.
Log Dog w/Back Stop	Log Dog (18/228) Dog Only (230/236)	2 Years - call your servicing Hud-Son Dealer.
Log Dog Only	Log Dog (18/228) Dog Only (230/236)	2 Years - call your servicing Hud-Son Dealer.
Track Wheel w/Replacement Bearing	WHE-40-12-53	2 Years - call your servicing Hud-Son Dealer.
Replacement Bearing for Track Wheel	BEA-03-12-24T	2 Years - call your servicing Hud-Son Dealer.
Pulley for Lift Cable	CAB-01-0532	1 Year - call your servicing Hud-Son Dealer.
Cheater	Oscar 18 - Cheater, Oscar 228 - Cheater	2 Years - call your servicing Hud-Son Dealer.
Guide Pins	MIL-10-0000-001	2 Years - call your servicing Hud-Son Dealer.
Modular Guide Tube	TUB-20-09, TUB-20-20, TUB-20-35	2 Years - call your servicing Hud-Son Dealer.
Bolt on Lube Tank	MIL-07-001	2 Years - call your servicing Hud-Son Dealer.

Parts and Warranty

Warranty:

Warranty registration cards must be completed and returned to Hud-Son Forest Equipment, Inc. within 30 days of purchase. Failure to do so will void the warranty!

Warranty claims must be registered with the Dealer/Distributor, and defective parts must be returned to the Dealer/Distributor at the owner's expense. The Dealer/Distributor will assume cost of the shipping one way in regards to any warranty claim. Freight is standard ground. Any expedited services are at an additional charge and will be paid in full before shipping at the owner's expense. The shipping of warranty/parts out of the continental USA, will not be covered under warranty. The labor charge out of the continental USA is also not covered under warranty.

The Oscar 52 has a 1 year warranty.

Fuel system problems caused by the failure to use fresh fuel (less than 30 days old) - Gummy deposits, varnish and/or corrosion due to old gas are not covered by warranty. Since we have no control over the quality of gasoline and we know it deteriorates with age, the warranty defines "fresh" fuel as less than 30 days old.

ALWAYS CALL YOUR SERVICING DEALER FIRST!!

Dealers/Distributors carry parts and are very knowledgeable with the inner workings of your sawmill. Remember that modifying your mill or using parts that are not Hud-Son Forest Equipment Inc approved, can void your warranty.

Warranty/Service Information:

Please contact our warranty department with any issues or to reorder parts.

315-896-4316 or 1-800-765-7297

Hours of operation are M-F 8:00 - 4:30 EST

*** HUD-SON DOES NOT PAY FREIGHT OR SHIPPING ON WARRANTY
OR LABOR IF NOT IN THE CONTINENTAL USA ***

Warranty Claim Procedure

All warranty claims that are done in the field will be handled as follows:

- 1 - Customer will call the Dealer/Distributor and acknowledge the problem.
- 2 - If the problem can be solved in the field, new parts will be shipped, invoiced and paid for. A credit will be given once the old parts are returned, if covered by warranty.
- 3 - If requested, parts to be replaced must be returned, at owner's expense within 30-days to receive credit.
- 4 - If the problem is deemed to severe to be fixed in the field by the customer, then the customer must bring the saw mill, at the owner's expense, to the closest Hud-Son Dealer/Distributor for repair. If the Dealer/Distributor is not qualified to make the repairs, then the equipment must be returned to Hud-Son Forest Equipment, Inc at the customer's expense.
- 5 - If the problem is deemed not to be a warranty problem, an invoice will follow for the parts that were replaced, as well as an invoice for any time spent on the mill by Hud-Son Forest Equipment, Inc staff and/or Dealer/Distributor staff.
- 6 - Any modification to the band mill that is performed by any personnel other than Hud-Son Forest Equipment, Inc direct staff voids the warranty.
- 7 - Any parts that are replaced without the discretion of the Dealer/Distributor voids the warranty on the part the customer is replacing and no reimbursement will be made.
- 8 - Parts purchased by the customer from an outside source, without prior approval from Hud-Son Forest Equipment, Inc will NOT be reimbursed.

Blade Guide

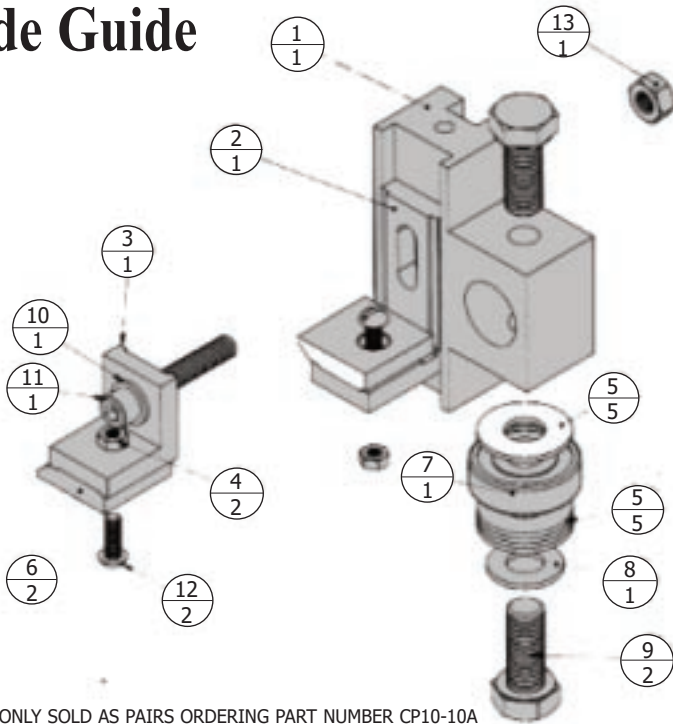

NOTE: ITEM 4 IS ONLY SOLD AS PAIRS ORDERING PART NUMBER CP10-10A
 INCLUDES TWO SHOES, TWO NUTS
 (ITEM 13, AND TWO SCREWS (ITEM 12))

Item No	Part No	Description	Qty.
1	LBG-40003	Guide Body	1
2	LBG-40001	Lower Shoe Holder	1
3	LBG-40002	Upper Shoe Holder	1
4	37406	8-32 LK. Nut	2
5	33082	3/8 Sae Washers	7
6	CPO10-10A	Guide Shoes	2
7	6300-2RS	6200-2RS Bearing	1
8	33082	3/8 Sae Washers	1
9	F-42865	3/8-16 x 1 1/2 Bolts	2
10	F-93368	1/4 Washer	1
11	35694	1/4-20 x 1 7/8 Bolt	1
12	F-64924-R	8-32 x 3/4 Screw	2
13	F-59756	1/4-20 Nylock Nut	1

Track Wheel Assembly Parts List

Item No.	Part No.	Description	Qty.
1	WHE-04-12-53	TRACK WHEEL	1
2	HAR-12-12-64	SHOULDER BOLT	1
3	HAR-55-12-1000-125	3/4"X1"X1/8" ZNFW	2
4	HAR-50-12-1166-76	3/4" ZFW	1
5	PIN-08-25	C-CLIP	1
6	BEA-03-12-24T	3/4" BEARING	1

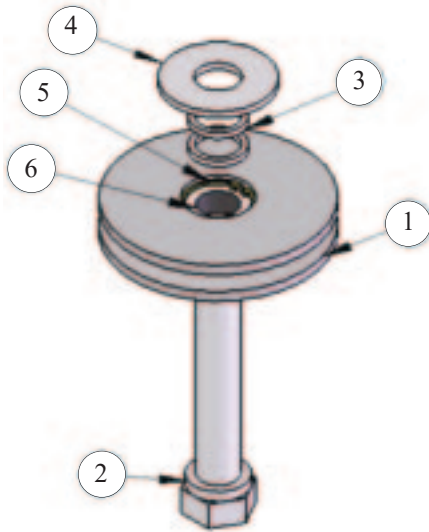

Site Glass Assembly Parts List

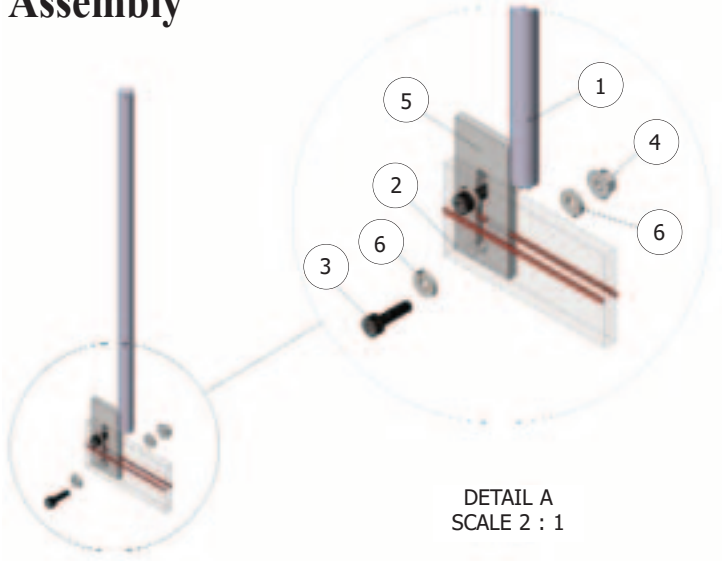

Item No.	Part No.	Description	Qty.
1	KIT-001	SIGHT GLASS BAR	1
2	KIT-001	SIGHT GLASS BAR	1
3	HAR-15-M10	10MM-1.5X25 8.8 Z	2
4	HAR-36-M10	M10-1.5 FLANGE NUT	2
5	KIT-001	O30/36 SIGHT GLASS BRACKET	1
6	HAR-51-03-438-047	#6 P FW	4

Large Dog

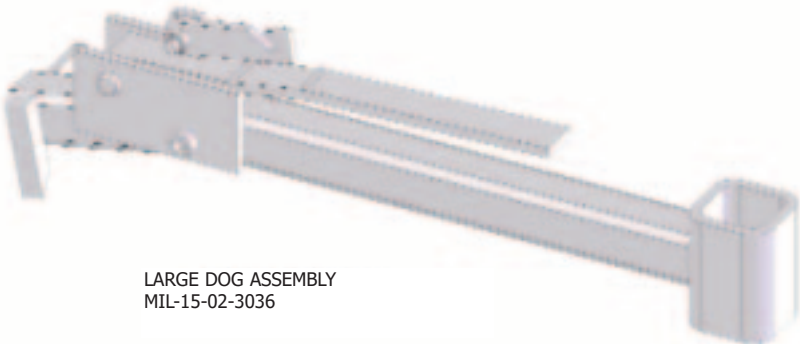

MAINTENANCE NOTES

MAINTENANCE NOTES

This manual is filled with the latest information and specifications at the time of publication. We have the right to make changes as they are needed. Any of the changes in our product may cause a variation between the illustrations and explanations in the manual and the item that you have purchased.

DISPUTES

All disputes, claims and causes of action arising out of the delivery, use, or warranty claims for personal injury and or property damage must:

1. Claimant must provide a written notice of the claim or dispute to the company (at the address below) at least 30 days after the claim arose prior to commencement of any action;
2. Company has 60 days to make a decision on the claim and will provide a written response to claimant;
3. No action may be commenced until after the company has provided its decision on the claim;
4. All claims against the company for any cause related to delivery, design defects, repairs, use of the equipment or warranty shall be filed in Supreme Court, Oneida County, State of New York. The parties may file for Arbitration in Oneida County New York after consent by both parties.
5. Construction and interpretation of this agreement and any and all claims shall be subject to the Laws of the State of New York.

6: The address for submission of claims is:

Hud-Son Forest Equipment
PO Box 345
8201 State Route 12
Barneveld, NY 13304

7. Notices under this agreement must be in writing and sent by certified or registered mail;

SET BLADE TENSION

Blade Tension is critical to achieve good cuts.

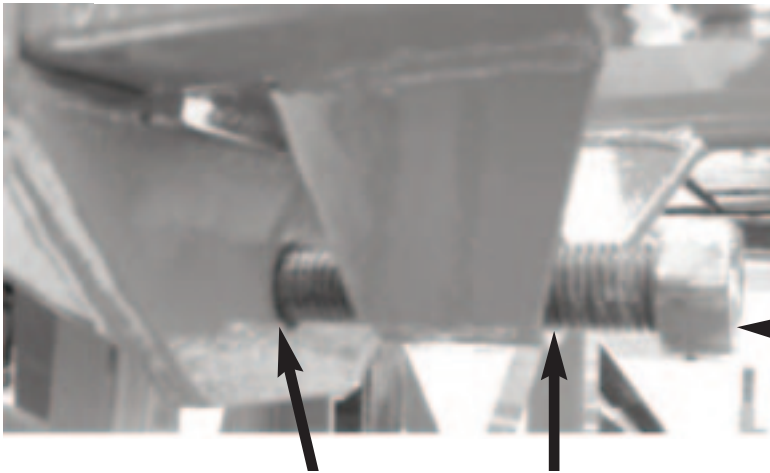

*Tension bolt for
(Oscar-52) 1 3/8"
bolt head*

Be sure to keep the Tensioner bolt well lubricated on the threads and on the end of the bolt on the push plate.
Set tension at 70 ft. lbs.

1. To tension the blade,

NOTE: When tensioning the Band Blade **periodically TURN THE BAND WHEEL!** so that the blade stretches evenly during the tensioning process.

2. Turn the adjusting bolt or stud, clockwise until 70 ft.lbs of torque is achieved. The recommended tool for this is a 1 3/8" socket with a torque wrench handle. **DO NOT OVER TENSION THE BLADE!!**

3. After setting the tension, run the mill at full rpm for a minute, stop the blade and check tension once more before cutting.

Note; if the Band blade is dull, It will get hot during a cut and can cause damage to the band wheel belts and guides.

If you do not have a torque wrench available.

tighten the tensioner bolt and **periodically TURN THE BAND WHEEL!** so that the blade stretches evenly during the tensioning process.

Pulling up on the blade in the center, you should not have any more than a 1/4" deflection. Then run the mill at full rpm for a minute, stop the blade and check tension once more before cutting. when running the mill check for flutter on the top side of the blade by looking at the back edge of the blade when running at full rpm. If the blade is fluttering up and down it is too loose. shut off and tighten another turn. check for flutter again.

Thank you for choosing



Hud-Son Forest Equipment, Inc.

8201 State Rt. 12, PO Box 345 Barneveld, NY 13304

info@hud-son.com

We have an onsite technician available to answer any questions you may have.

Contact Hud-Son Forest Equipment at 315-896-7297.

WWW.HUD-SON.COM • 800.765.SAWS